

Corner Bottom L 1 off		
ITEM	QTY	PART NUMBER
1	1	Corner Bttm Bttm
2	1	Corner Bttm Mid
5	8	M3 x 25 Cap Head BZP
6	8	M3 Nut Full BZP.ipt
7	16	M3 Washer BZP
8	2	M5 Nut Full BZP
9	2	M5 x 6 Grub Screw
13	1	Corner Bttm L Bearing
14	1	608ZZ Bearing

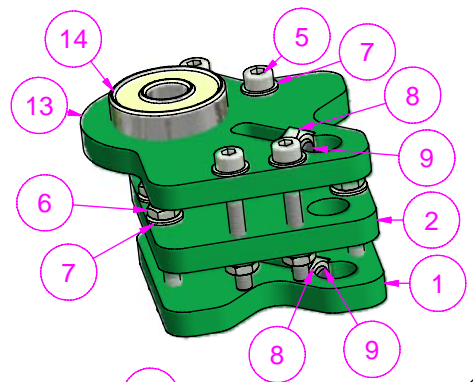

Corner Z Motor 1 off		
ITEM	QTY	PART NUMBER
1	1	Corner Bttm Bttm
2	1	Corner Bttm Mid
3	1	Corner Bttm L Motor
4	1	Corner Z Motor Mount
5	8	M3 x 25 Cap Head BZP
6	8	M3 Nut Full BZP.ipt
7	16	M3 Washer BZP
8	6	M5 Nut Full BZP
9	2	M5 x 6 Grub Screw
11	4	M5 Washer BZP
12	4	M5 x 20 Cap Head BZP
53	1	FL57STH56-3008B

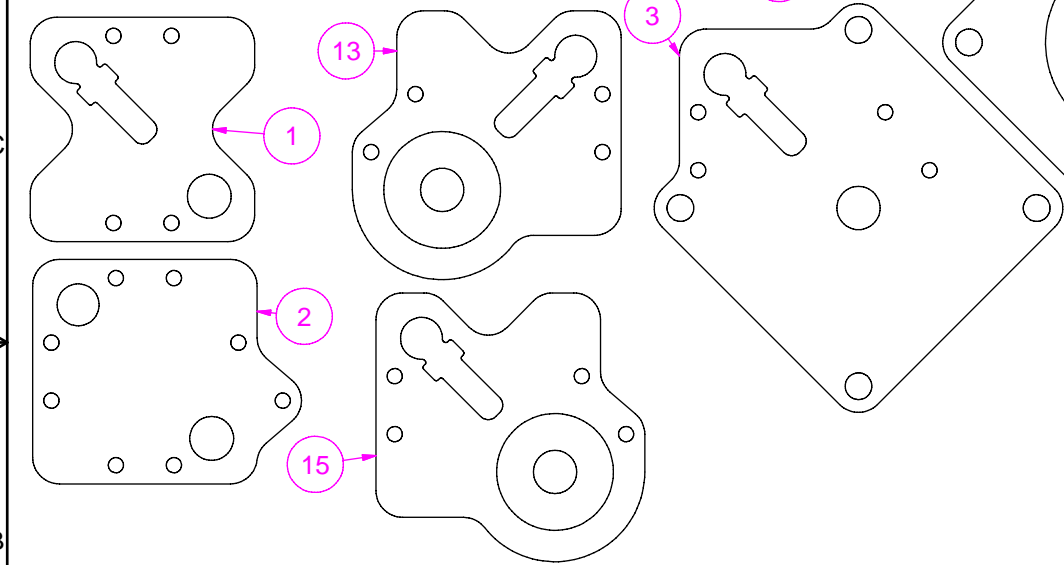
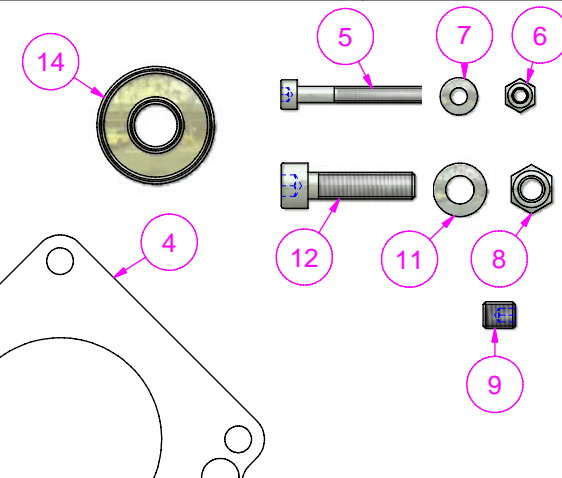

Corner Bottom R 2 off		
ITEM	QTY	PART NUMBER
1	1	Corner Bttm Bttm
2	1	Corner Bttm Mid
5	8	M3 x 25 Cap Head BZP
6	8	M3 Nut Full BZP.ipt
7	16	M3 Washer BZP
8	2	M5 Nut Full BZP
9	2	M5 x 6 Grub Screw
14	1	608ZZ Bearing
15	1	Corner Bttm R Bearing

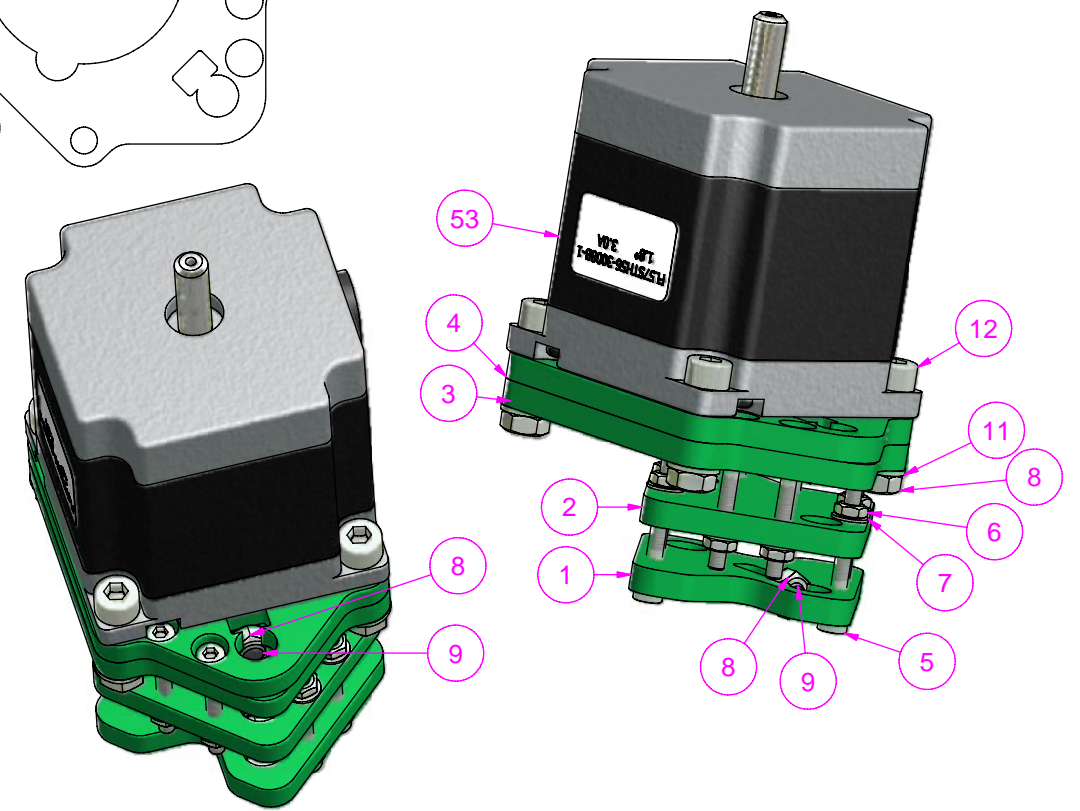
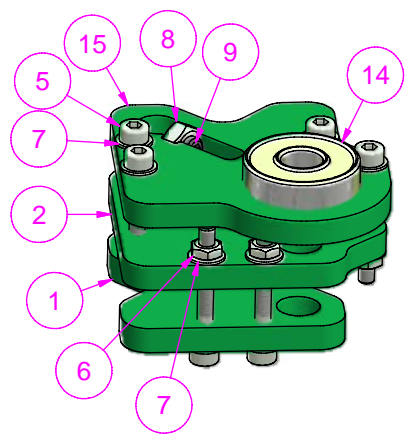

Designed by Ian Adkins	Checked by	Approved by - date	Date 27/07/2008
		Corner Blocks Bottom	
		Edition	Sheet 1 / 1