

Parts List		
ITEM	QTY	PART NAME
1	1	Main Plate
2	2	608ZZ Bearing
3	1	Bearing Lower Clamp Plate
4	1	Bearing Floating Plate
5	1	Top Plate
6	1	Insulator Retainer
7	1	Insulator Top Disc
8	1	M8 Nut Full BZP
9	1	M8 x 80 Hexagon Set BZP
10	1	Drive Spacer
11	1	Motor Mount
12	1	GM3 Motor
13	1	Opto Wheel Spacer
14	1	Opto Mount
15	1	Opto Wheel
16	1	Opto Slotted Disc
17	2	M5 x 30 Hexagon Head BZP
18	27	M3 Washer BZP
19	3	M3 x 25 Cap Head BZP
20	2	M3 x 30 Cap Head BZP
21	21	M3 Nut Full BZP.ipt
22	3	M3 x 16 Cap Head BZP
23	5	M5 Nut Full BZP
24	2	M5 x 25 Hexagon Head BZP
25	5	M5 Washer BZP
26	1	Drive Gear 20T
27	1	Driven Gear 40T
28	1	625 2Z Bearing
29	3	304 3181 415 56 M3 Spacer 18mm
30	12	M3 Washer SS
31	1	M6 x 30 Washer SS
32	1	311 3225 400 50 M3 Spacer 25mm
33	1	M6 x 18 Washer SS
34	3	M6 Nut Half SS
35	1	PTFE Insulator
36	1	Copper Shield
37	2	Pressure Clamp Plate
38	1	Fan 80mm
39	1	M5 x 30 Cap Head BZP
40	4	M3 x 35 Cap Head BZP
41	1	Reaction Plate
42	2	M3 x 12 Cap Head BZP
43	3	M3 x 20 Cap Head BZP
44	3	M3 x 16 Cap Head SS
45	4	M094404
46	1	Brass M4 Nozzle
47	1	2_28 x 3_4 Plas-Fix PLW0588
48	1	Fire Cement
49	1	NiChrome Wire

Designed by Ian Adkins	Checked by	Approved by - date	Date 17/07/2008
		Extruder Assembly	
		Extruder GA	Edition 1 / 4 Sheet 1 / 4

# Step 1

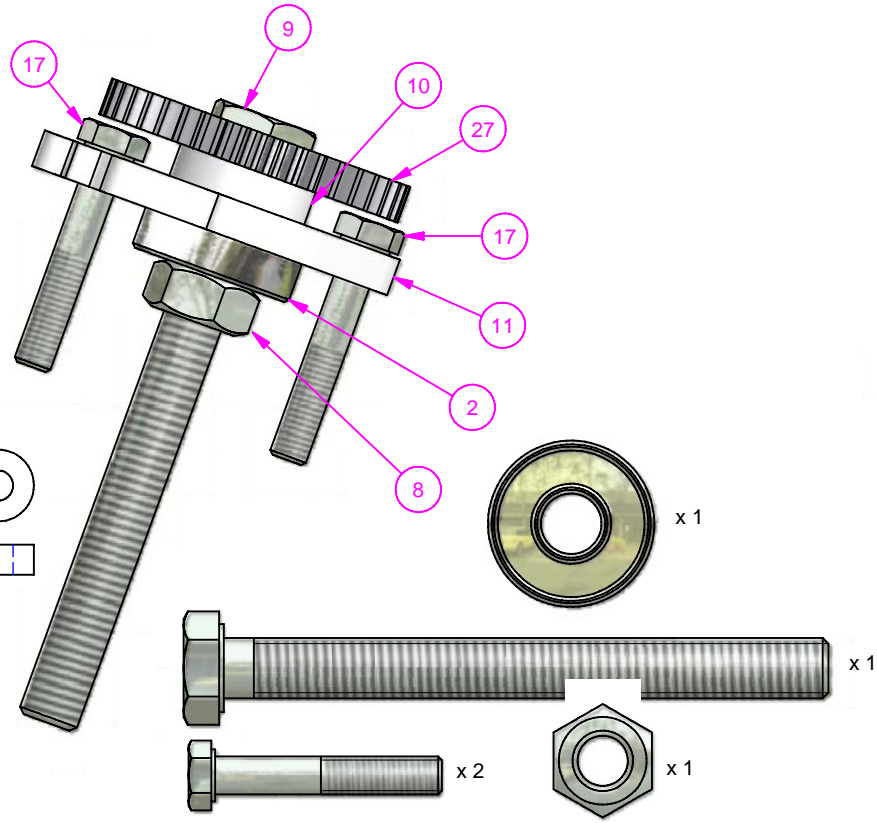
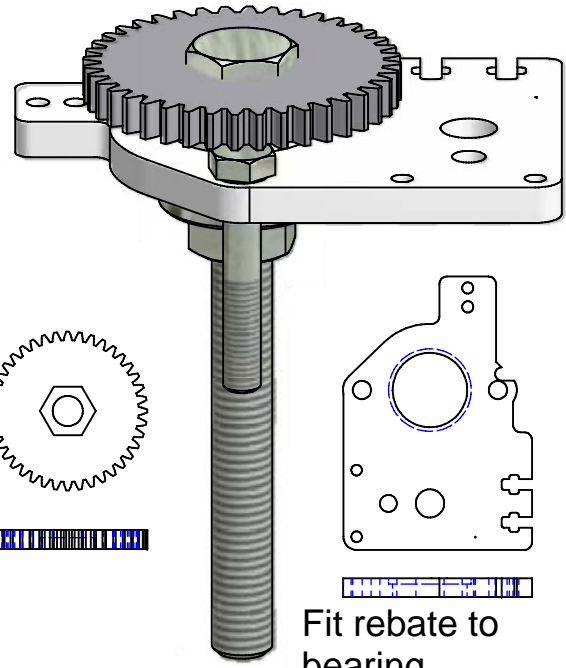

# Step 2

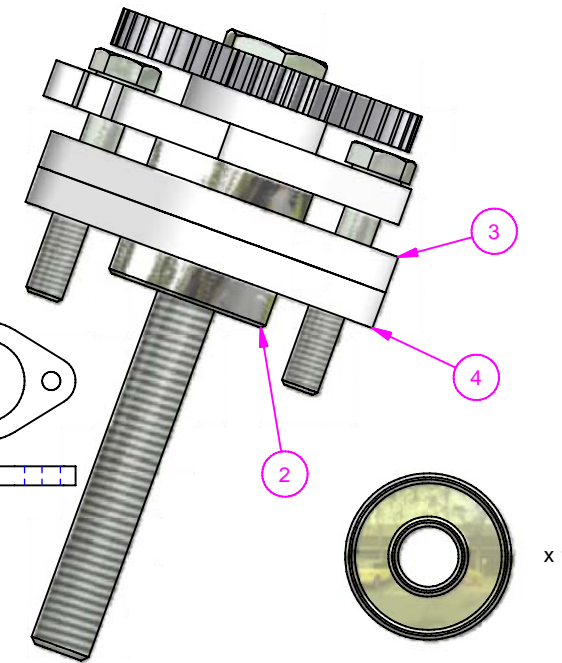
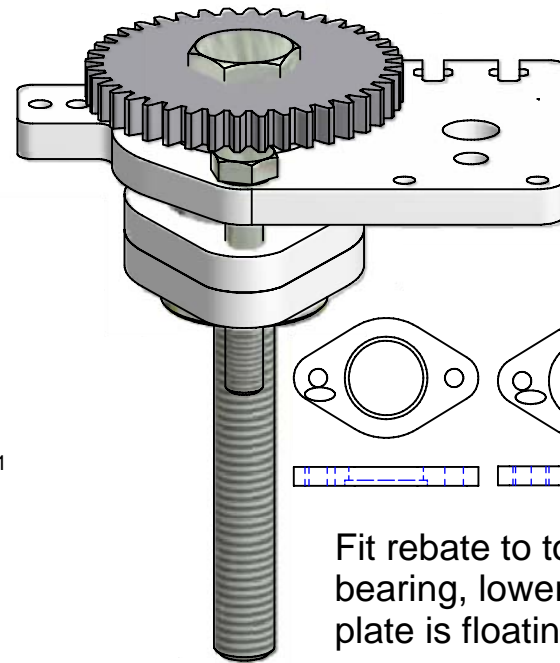

# Step 3

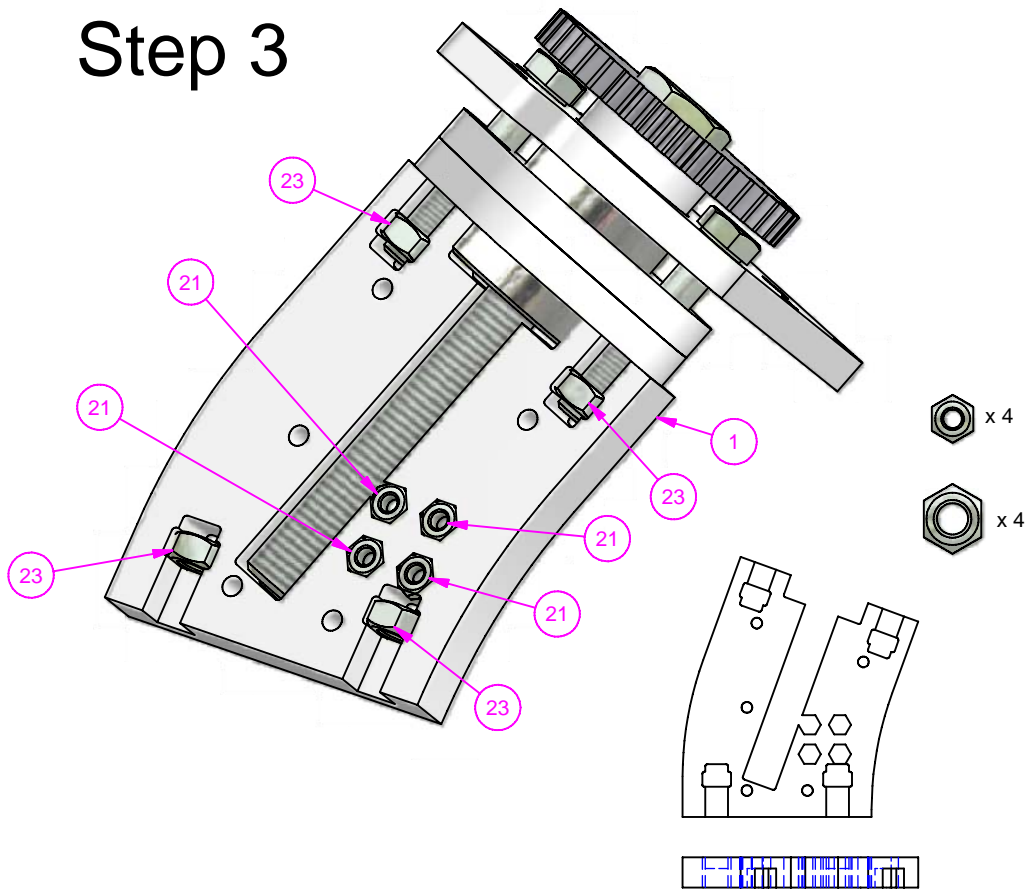

# Step 4

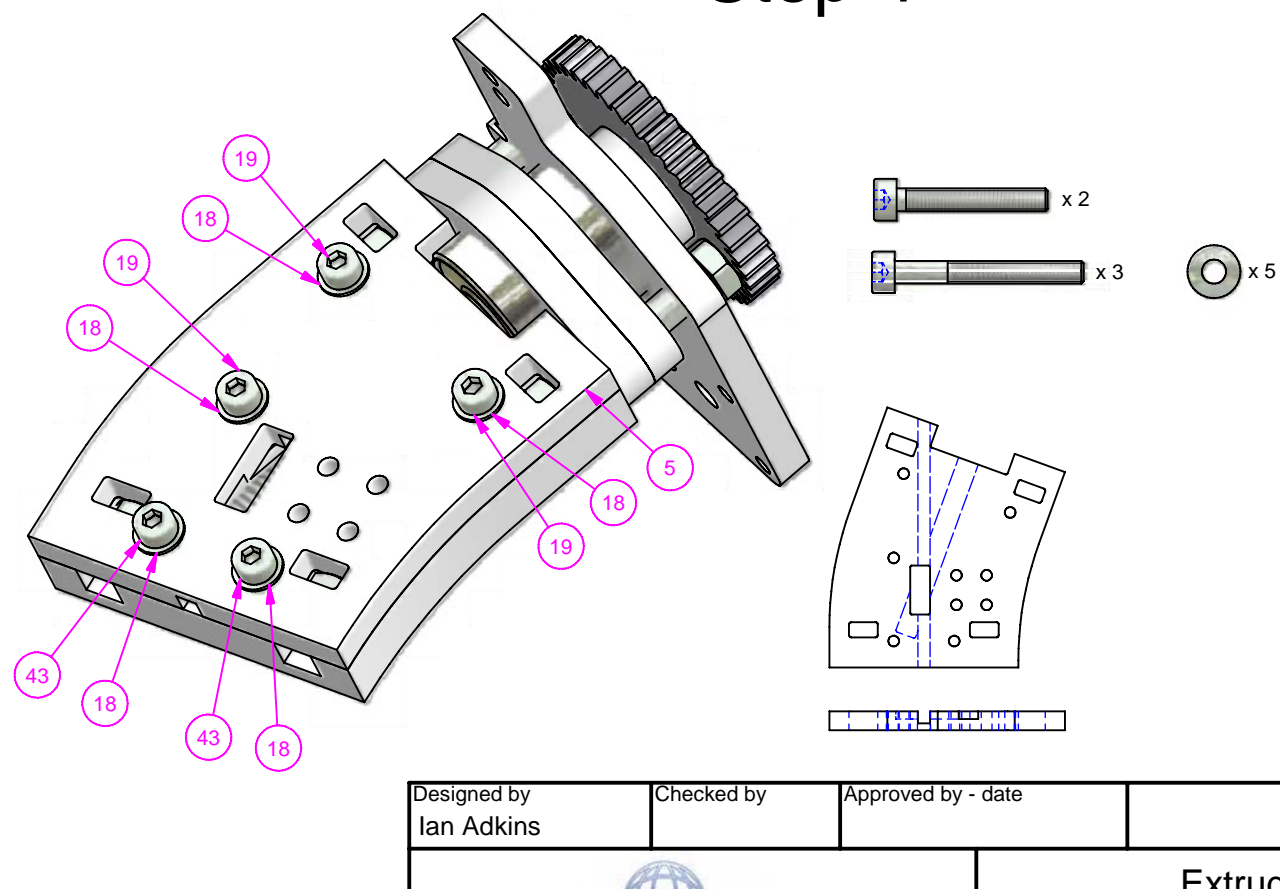

Designed by Ian Adkins	Checked by	Approved by - date	Date 17/07/2008
		Extruder Assembly	
		Extruder GA	Edition Sheet 2 / 4

6 | 5 | 4 | 3 | 2 | 1

D

C

B

A

D

C

B

A

### Step 5

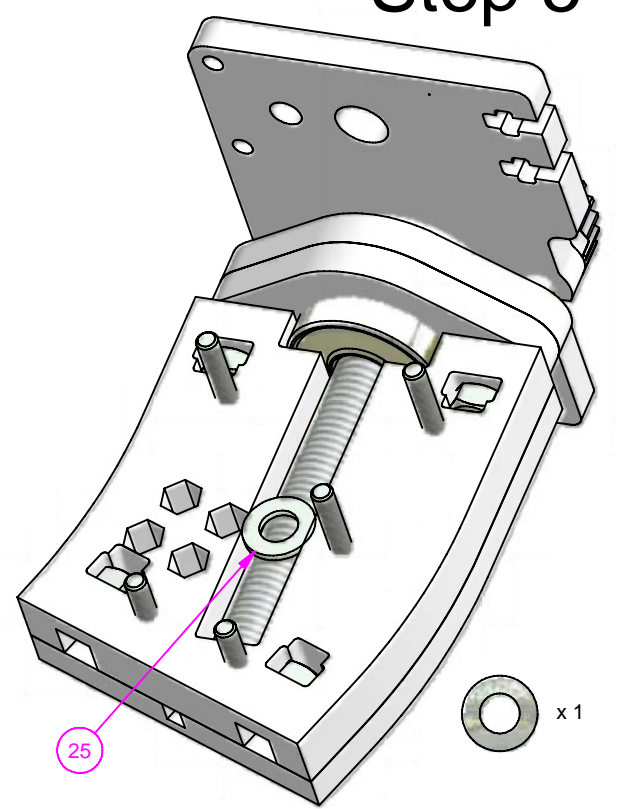

### Step 6

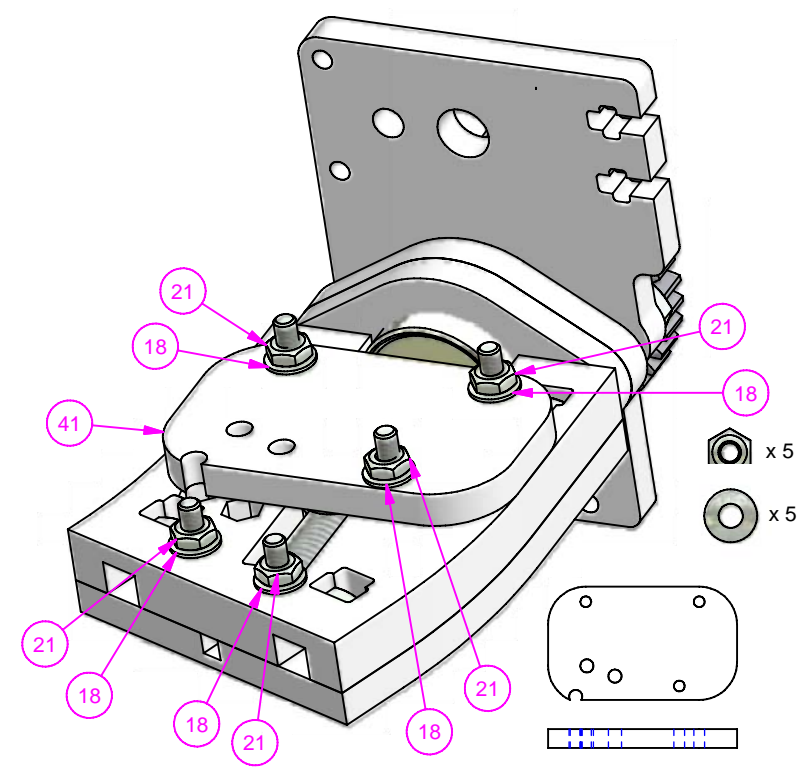

### Step 7

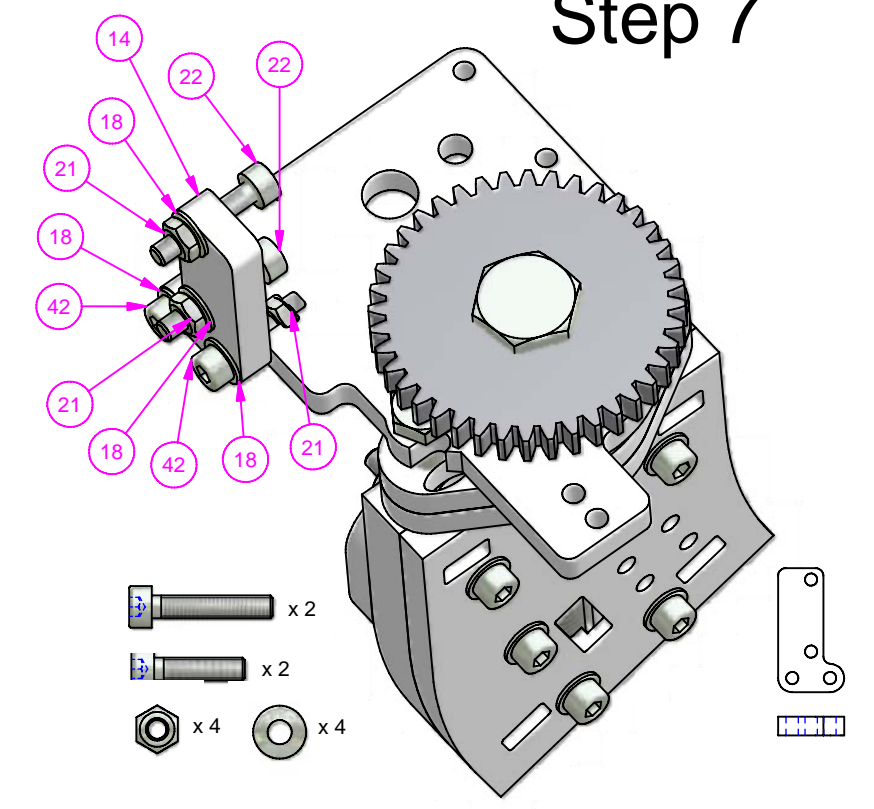

### Step 8

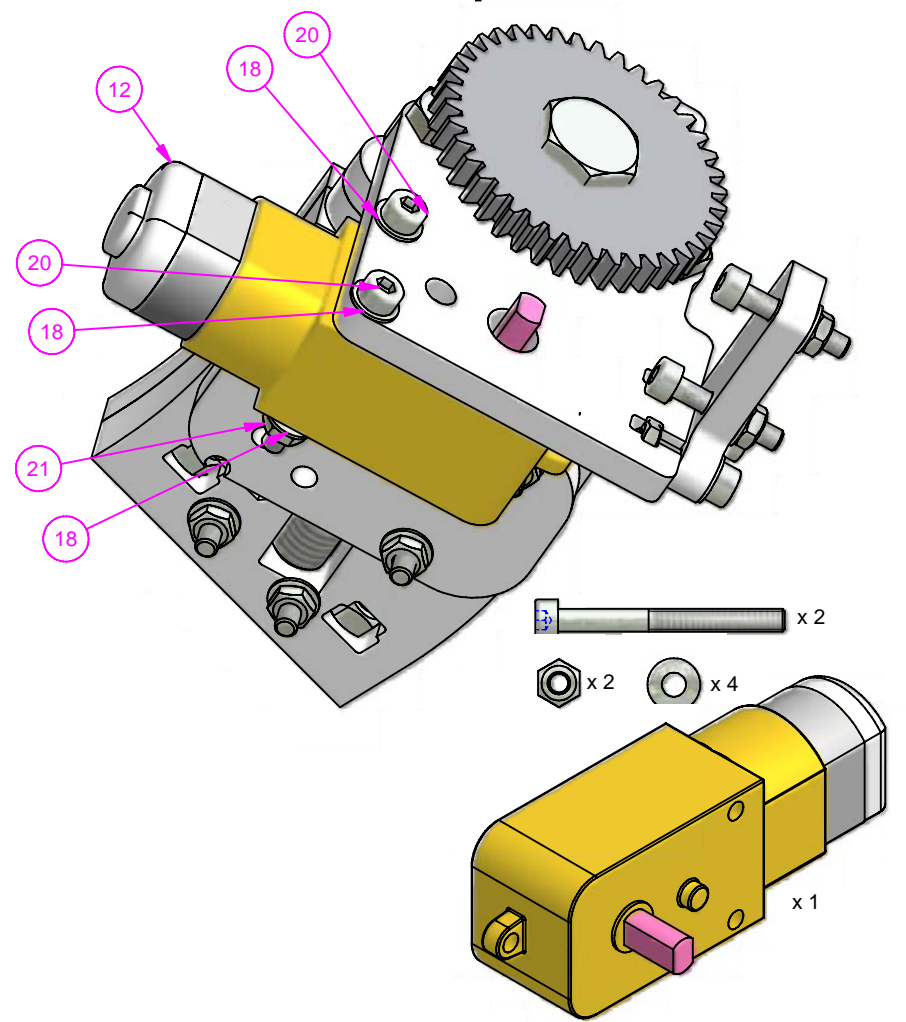

### Step 9

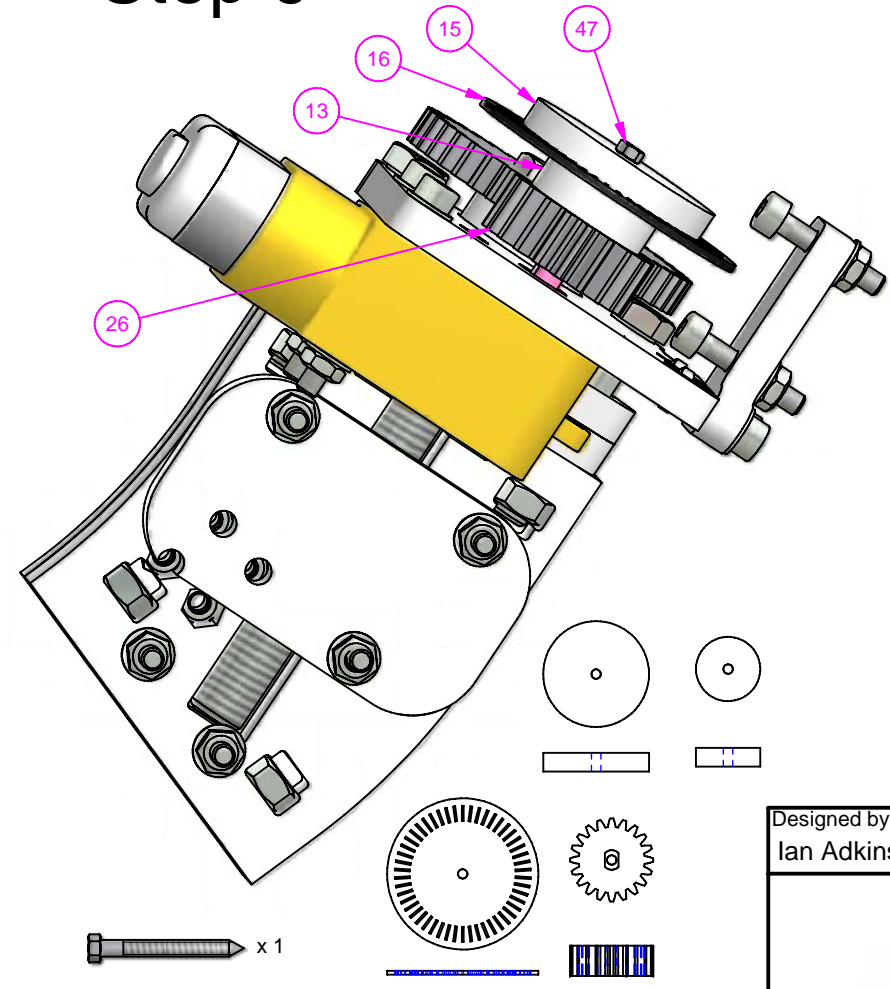

### Step 10

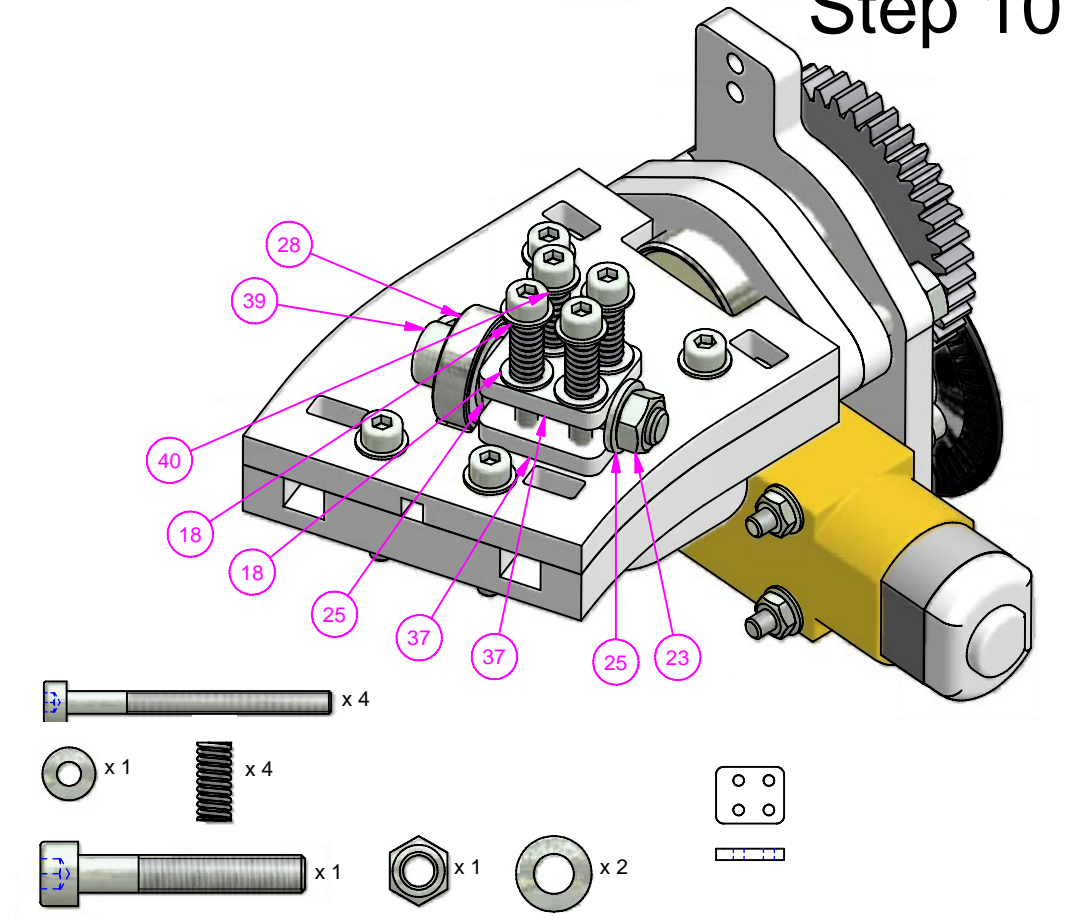

Designed by Ian Adkins	Checked by	Approved by - date	Date 17/07/2008
		Extruder Assembly	
		Extruder GA	Edition 3 / 4 Sheet 3 / 4

6 | 5 | 4 | 3 | 2 | 1

# Step 11

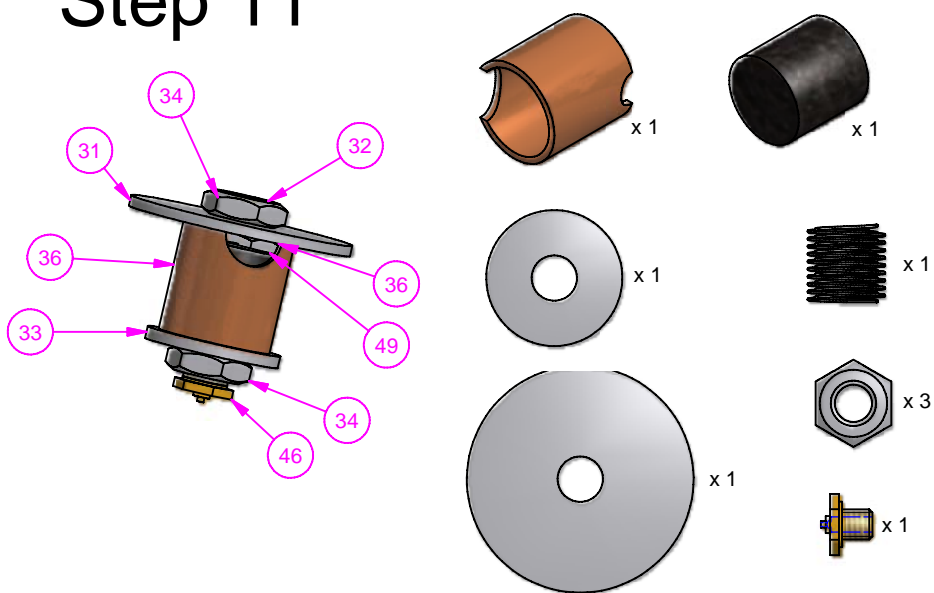

# Step 12

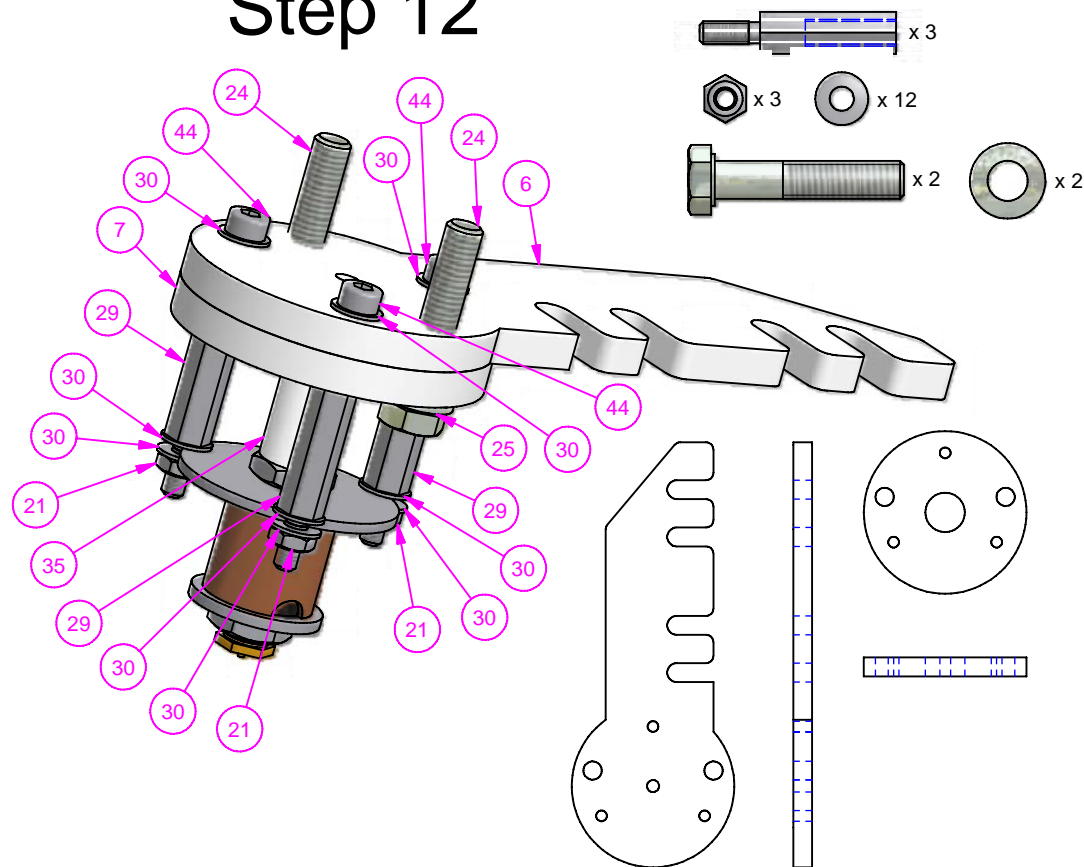

# Step 13

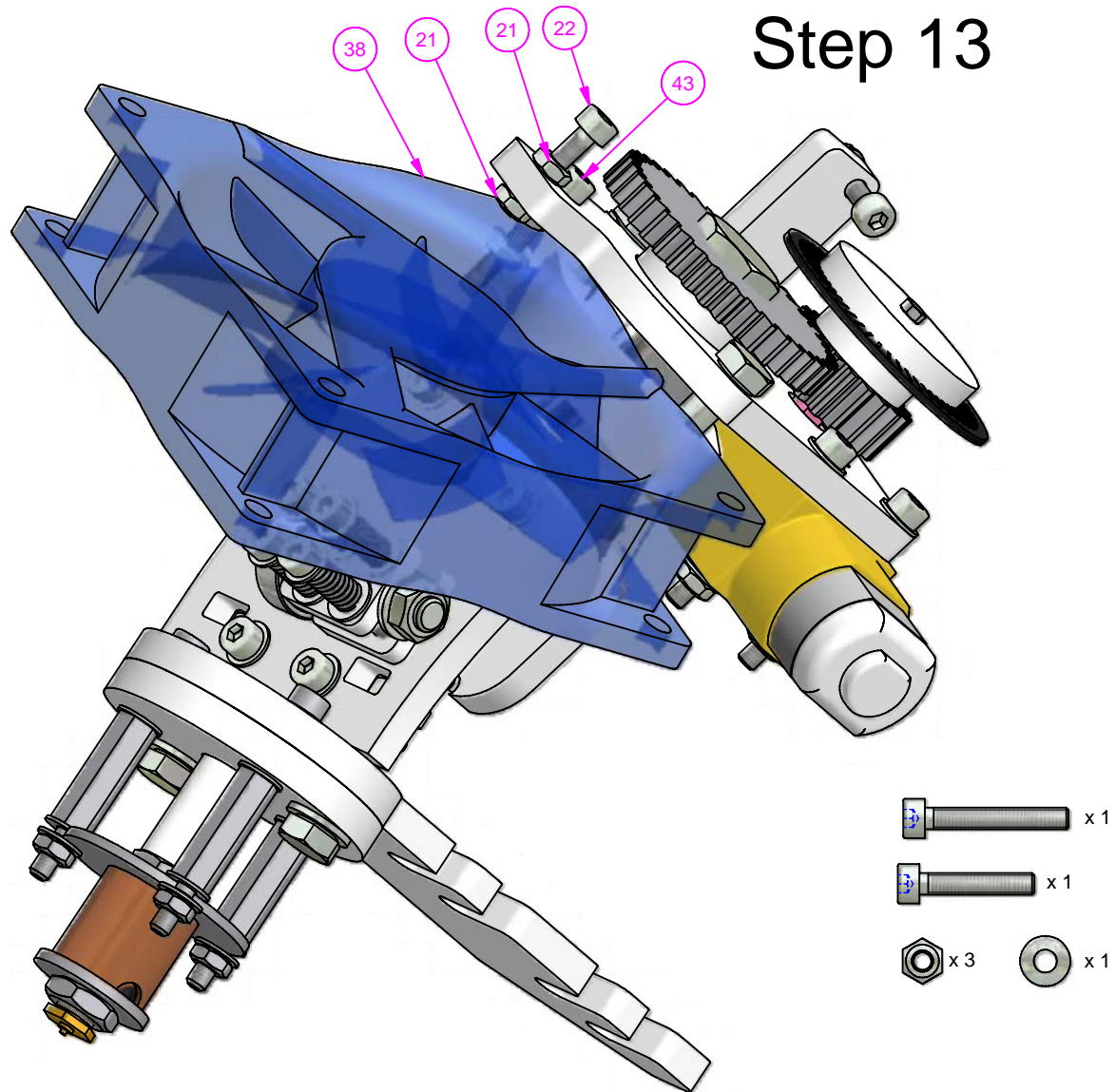

Designed by Ian Adkins	Checked by	Approved by - date	Date 17/07/2008
		Extruder Assembly	
		Extruder GA	Edition 4 / 4 Sheet 4 / 4