

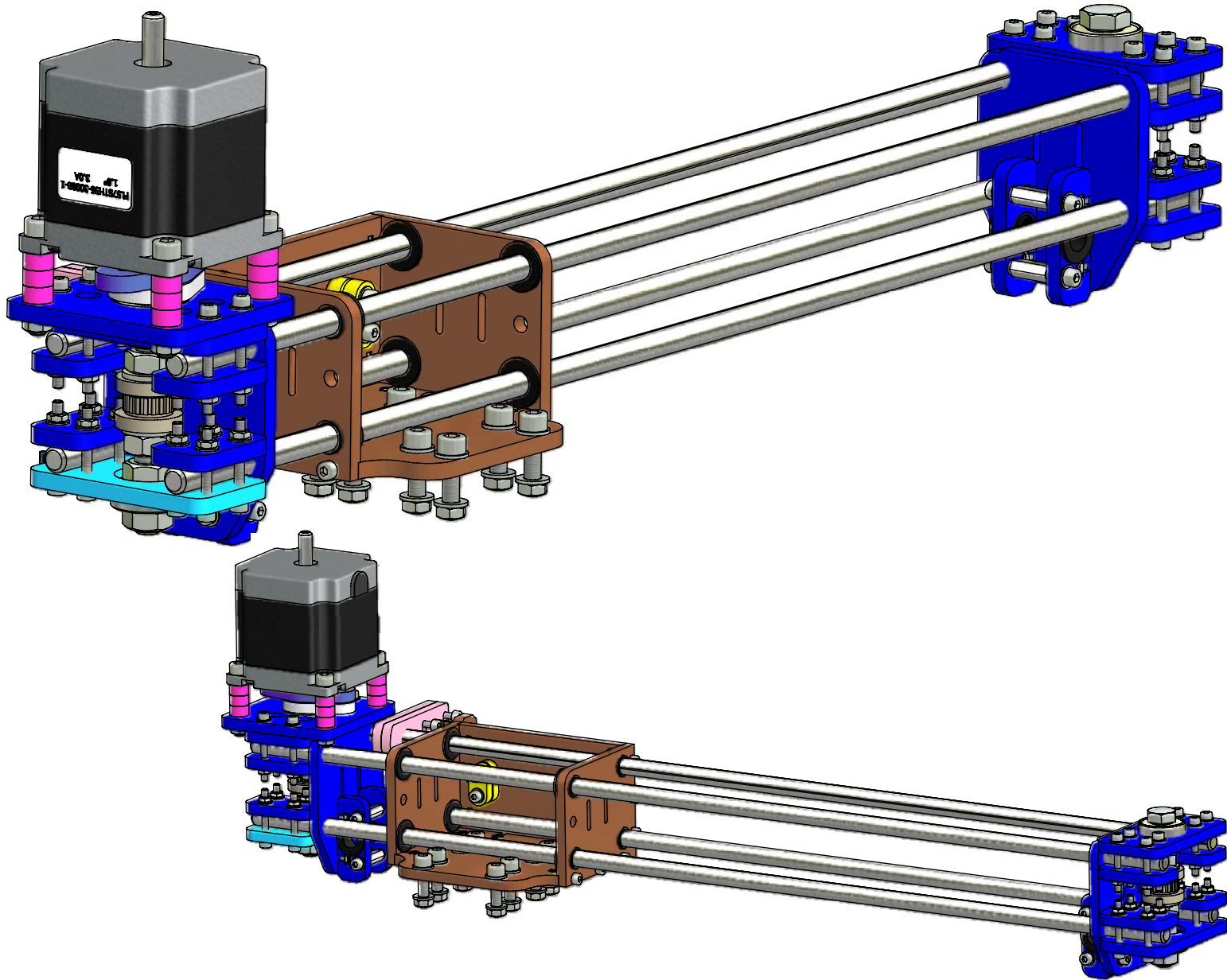

X Assembly		
ITEM	QTY	PART NUMBER
5	28	M3 x 25 Cap Head BZP
6	66	M3 Nut Full BZP.ipt
7	92	M3 Washer BZP
8	13	M5 Nut Full BZP
9	1	M5 x 6 Grub Screw
11	16	M5 Washer BZP
12	8	M5 x 20 Cap Head BZP
14	4	608ZZ Bearing
16	4	8Ø 500mm Plain
20	10	M8 Nut Full BZP
23	4	M8 Washer BZP
27	4	301 3150 599 34 M3 Spacer 15mm
29	12	008 7150 114 42 8Ø Slide Bearing
30	29	M3 x 12 Cap Head BZP
42	2	Rod Plate
43	4	Slide Adjuster
44	3	Idle Bearing Mount
45	8	Clamp Plate
46	2	20T Pulley
47	4	20T Flange
48	2	M8 x 70 Hexagon Set BZP
49	1	Motor Mount
50	1	1-4 Motor Plate
51	1	M8 Driven
52	12	Motor Spacer
53	1	FL57STH56-3008B
54	1	Idle Bearing Mount inc Opto Flag
55	4	M3 x 30 Cap Head BZP
56	4	M5 x 30 Cap Head BZP
57	1	M3 x 6 Cap Head BZP
58	1	Base
59	1	End Plate L
60	1	End Plate R
61	1	Back
62	2	Belt Clamp Retained Nut
63	2	Belt Clamp
64	7	M3 x 20 Cap Head BZP
65	1	X Opto Flag-1
66	1	X Opto Flag-2
67	1	Opto Switch Bracket R
68	1	Opto Switch Bracket L
83	1	M3 x 6 Grub Screw



Designed by Ian Adkins	Checked by	Approved by - date	Date 22/05/2008
		X Assembly	
		Edition	Sheet 1 / 6

Step 1

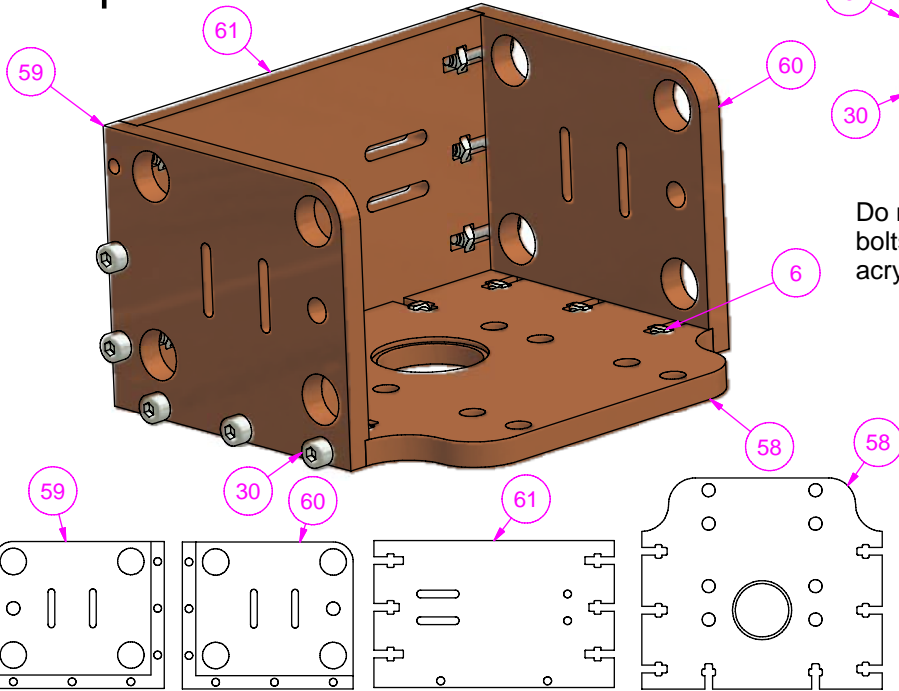

- 6 x 15
- 30 x 14

Do not overtighten the bolts as this will crack the acrylic.

The laser cut parts have a small taper on all cut edges, this makes it easier to insert the captive nuts from the top face as shown on the laser cut parts layout drawing

Step 2

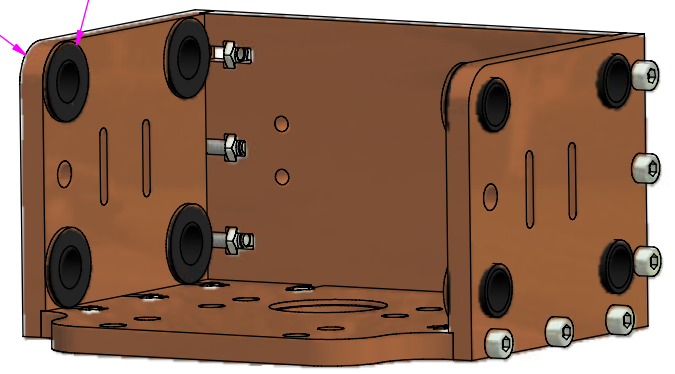

Before fitting the slide bearings ensure the small tab on the internal diameter has been removed

- 29 x 8

Step 3

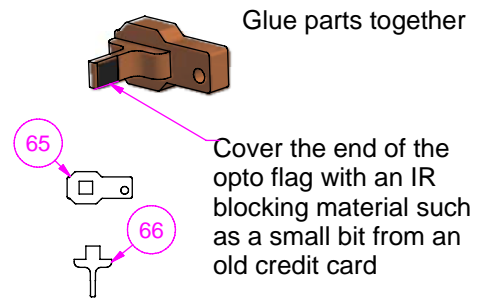

Glue parts together

Cover the end of the opto flag with an IR blocking material such as a small bit from an old credit card

Step 4

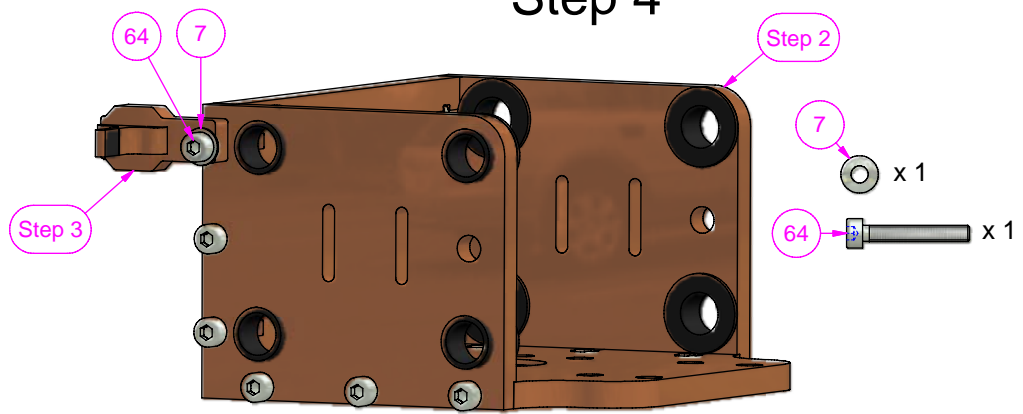

- 7 x 1
- 64 x 1

Designed by Ian Adkins	Checked by	Approved by - date	Date 22/05/2008
		X Assembly	
		Edition	Sheet 2 / 6

Step 5

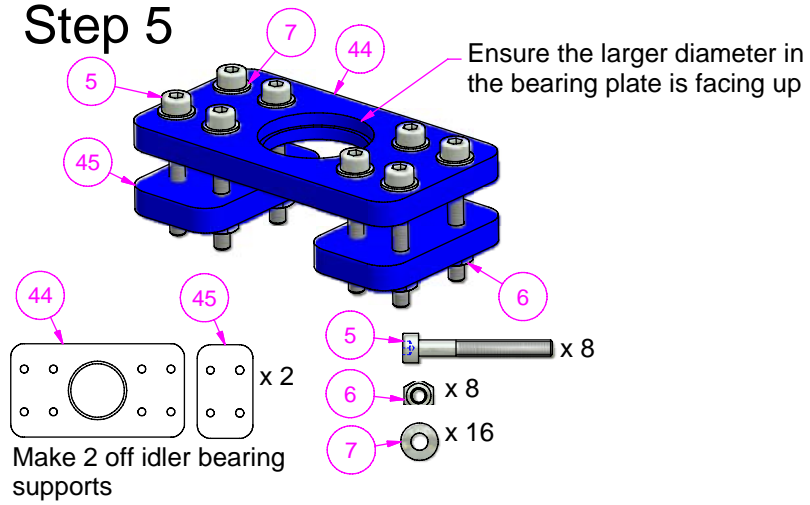

Step 6

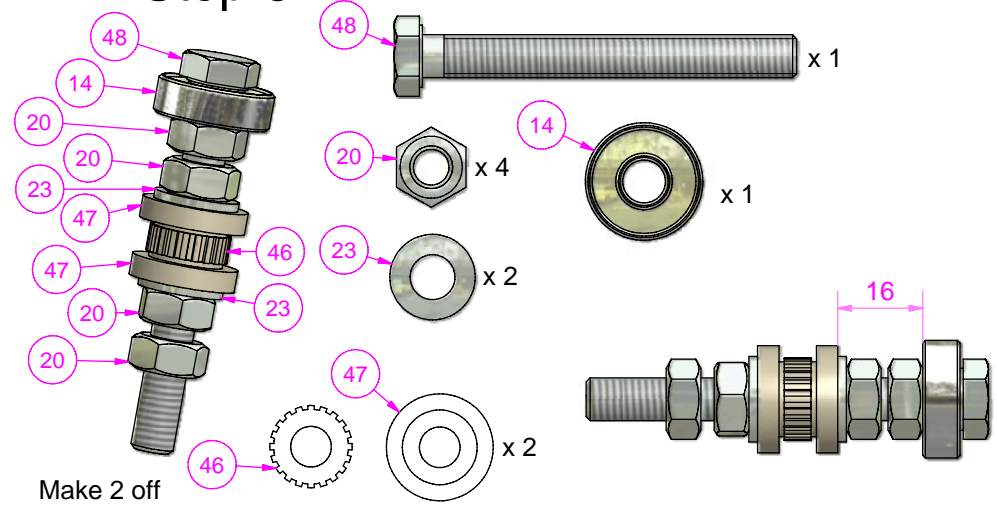

Step 7

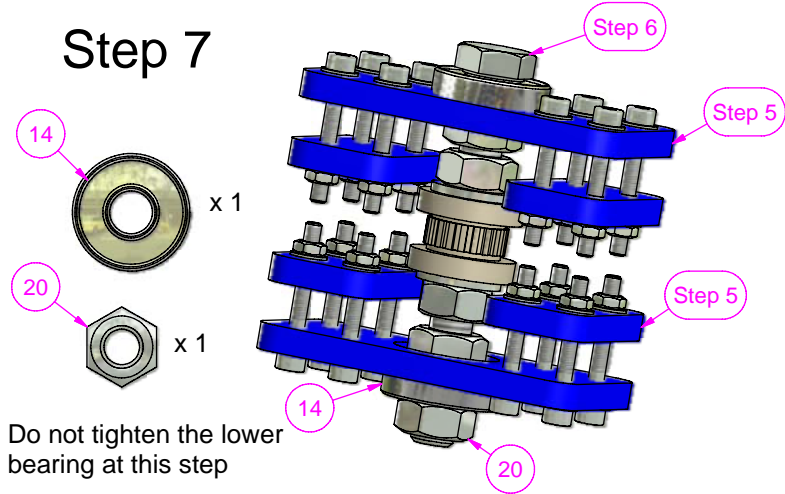

Step 8

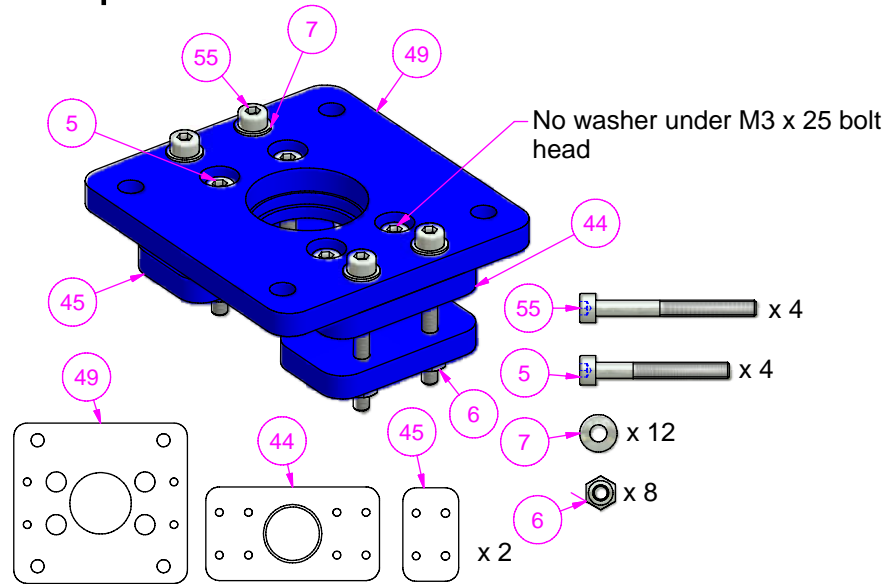

Designed by Ian Adkins	Checked by	Approved by - date	Date 22/05/2008
		X Assembly	
		Edition	Sheet 3 / 6

Step 9

Cover the end of the opto flag with an IR blocking material such as a small bit from an old credit card

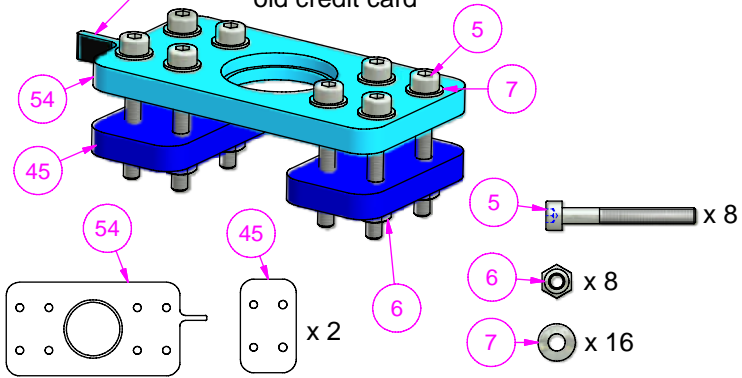

Step 10

Push fit onto the bolt head

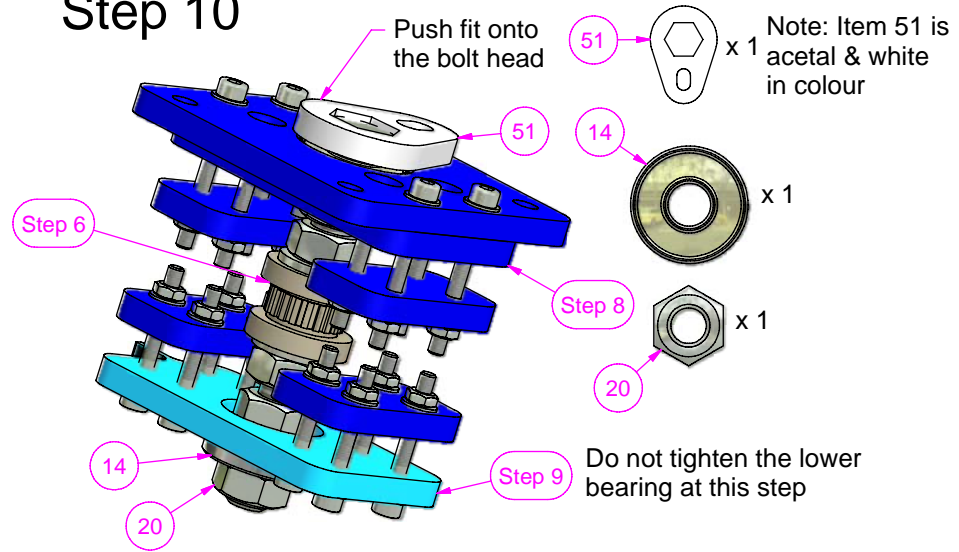

Step 11

Do not tighten slide bolts at this step

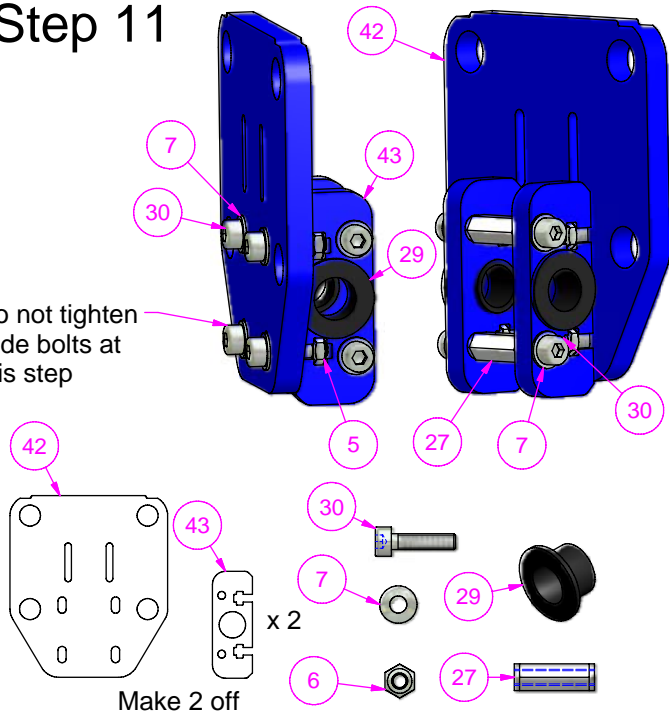

Step 12

Step 4

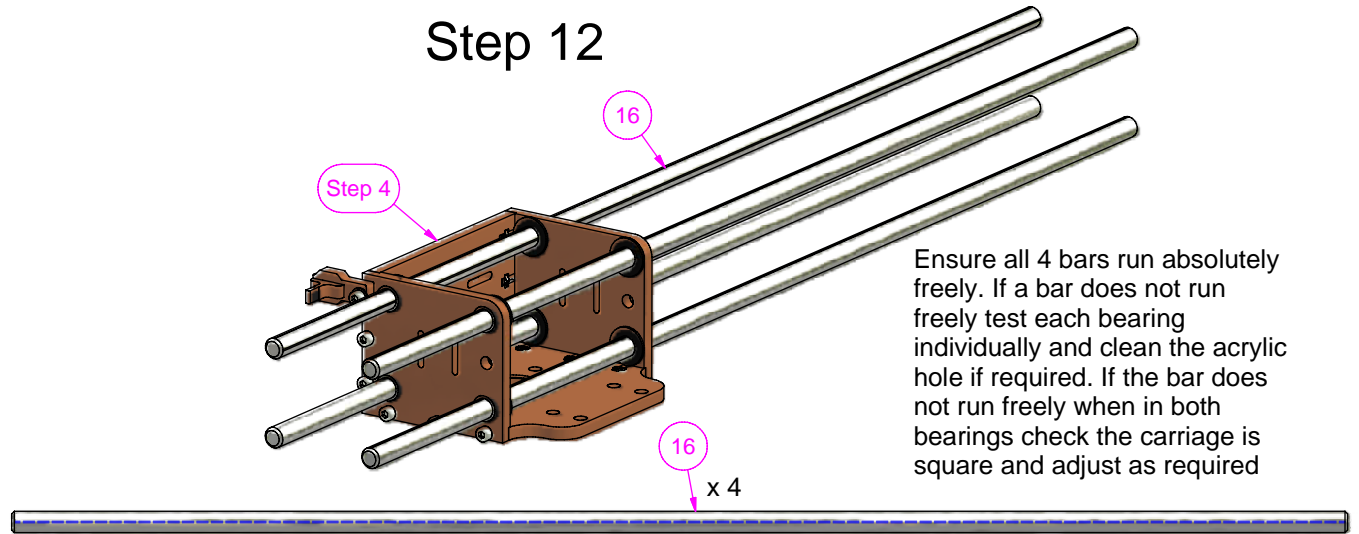

Designed by Ian Adkins	Checked by	Approved by - date	Date 22/05/2008
		X Assembly	
		Edition	Sheet 4 / 6

Step 13

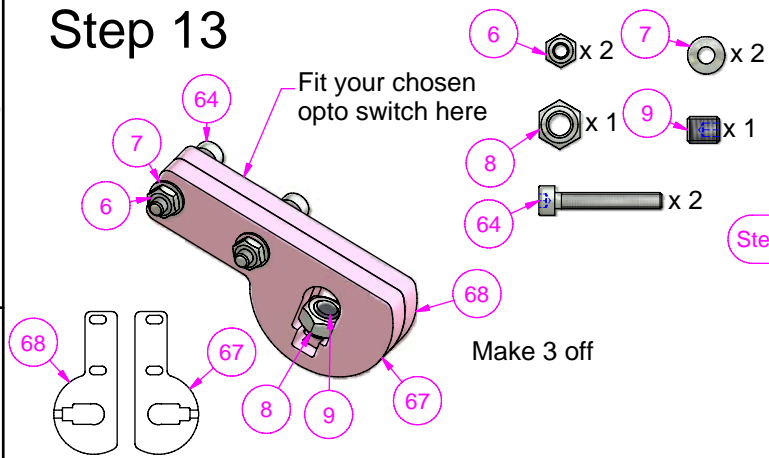

Step 14

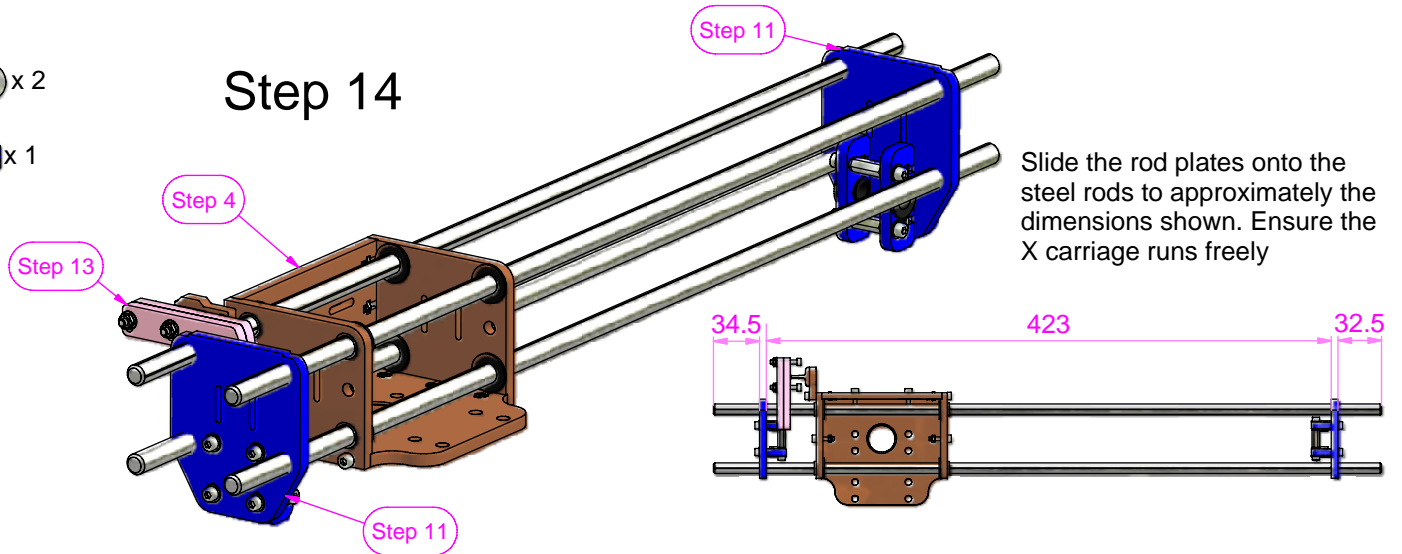

Step 15

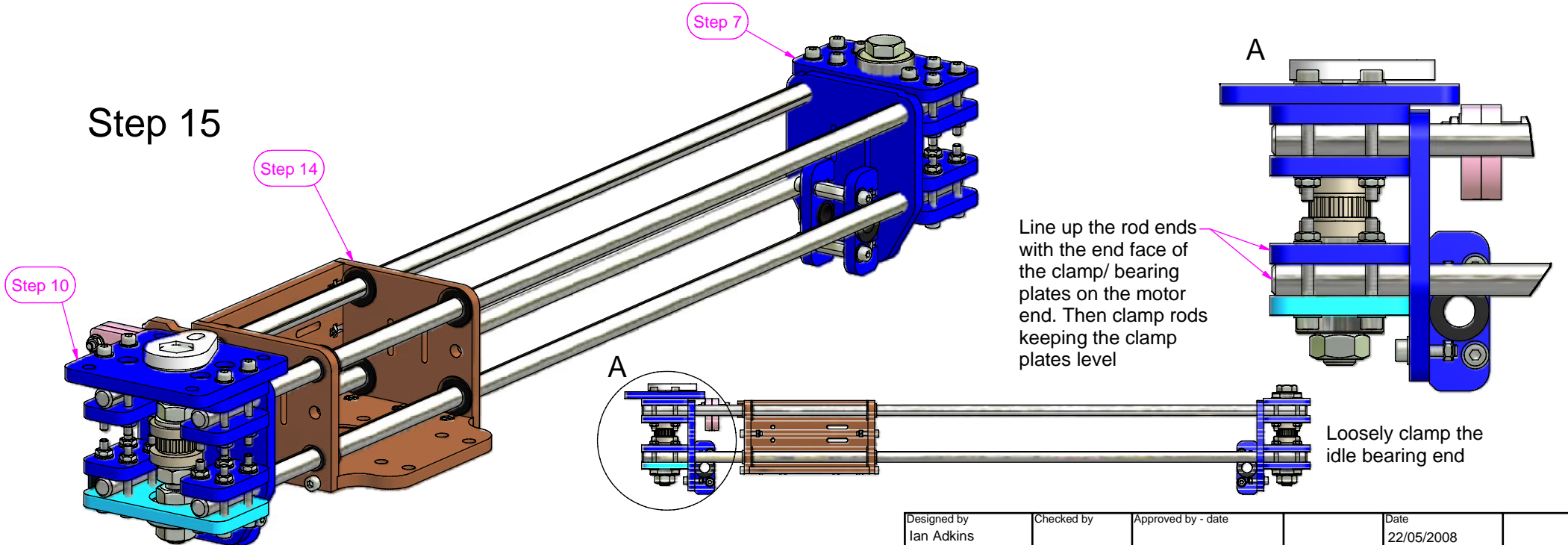

Designed by Ian Adkins	Checked by	Approved by - date	Date 22/05/2008
		X Assembly	
		Edition	Sheet 5 / 6

Step 16

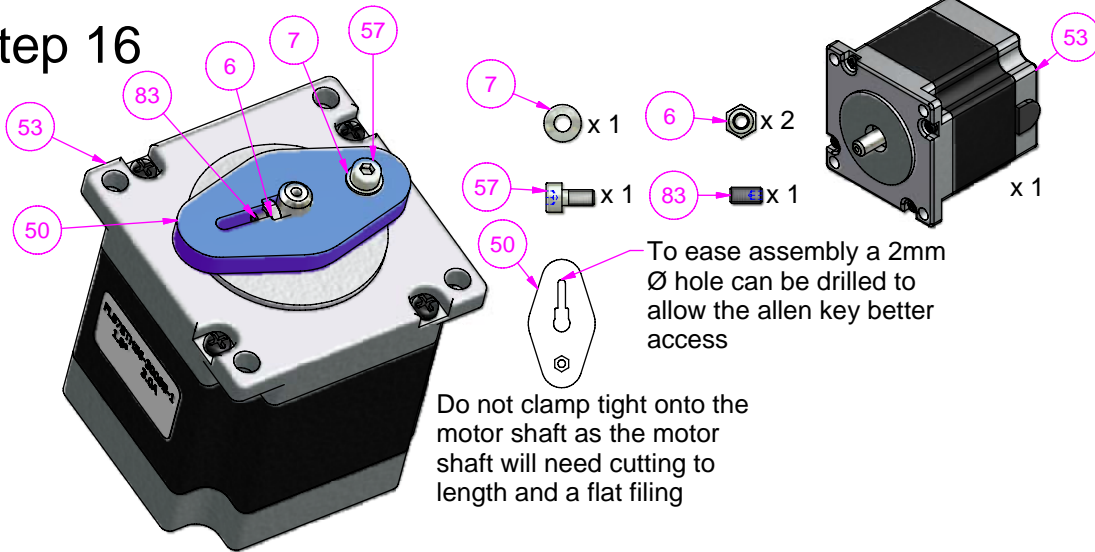

Test fit the motor assembly from step 16 and cut the motor shaft to the required length. File a small flat on the motor shaft where the grub screw engages.

Step 17

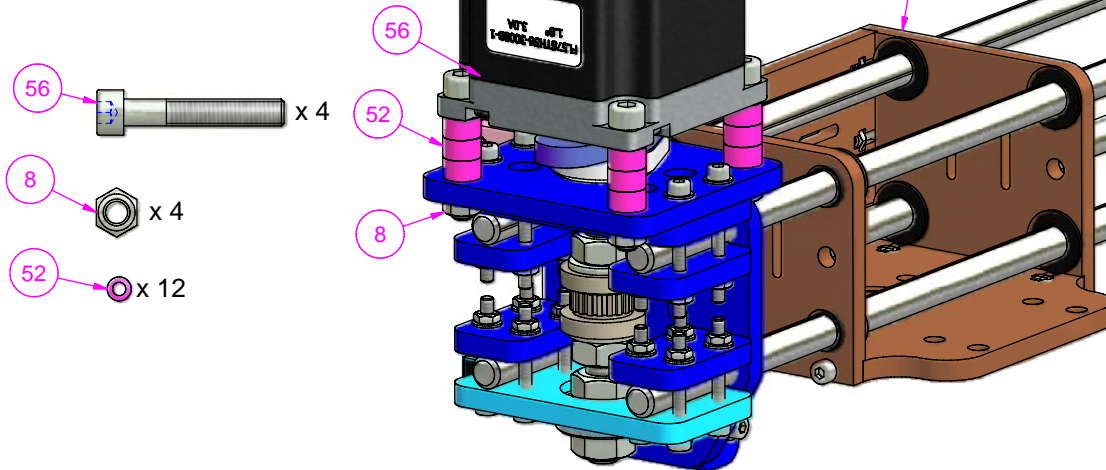

That completes the X axis assembly, set aside for later

Designed by Ian Adkins	Checked by	Approved by - date	Date 22/05/2008
		X Assembly	
		Edition	Sheet 6 / 6