

UNIVERSITÉ DE GENÈVE

Designing Fault-Tolerant Mobile Systems

Giovanna Di Marzo Serugendo
University of Geneva, Switzerland

Alexander Romanovsky
University of Newcastle upon Tyne, UK

Fidji'02 / November 2002 Giovanna Di Marzo Serugendo

Outline

- ▶ Mobile Agents
- ▶ Fault-Tolerance and Mobile Agents
- ▶ Example
 - Electronic marketplace using mobile e-purses
- ▶ Techniques
 - Meta-Agent
 - Coordinated Atomic Actions
 - Asynchronous resolution
 - Self-Repair
 - Proof Carrying Code

2

Mobile Agents = ...

- ▶ Agents
 - Autonomous running entities, able to take decisions and initiatives
 - Work on behalf of some user (or other system)
 - Several agents can work co-operatively (to solve some task) or in **competition** (for acquiring some resource)
- ▶ Mobile agents
 - Moves from one platform to another
 - Weak mobility: code only moves, not internal state;
 - Strong mobility: both code and internal state moves, execution is resumed at remote location

3

Mobile Agents = ...

- ▶ Mobile Systems characteristics:
 - Open: an agent interacts with other agents or systems
 - Large-scale size (agents roam the whole Internet)
 - Asynchronous communication (use of a blackboard)
 - Decentralised (no central control)
- ▶ Platforms
 - Need of full portability of mobile code
 - Usually Java-based platforms

4

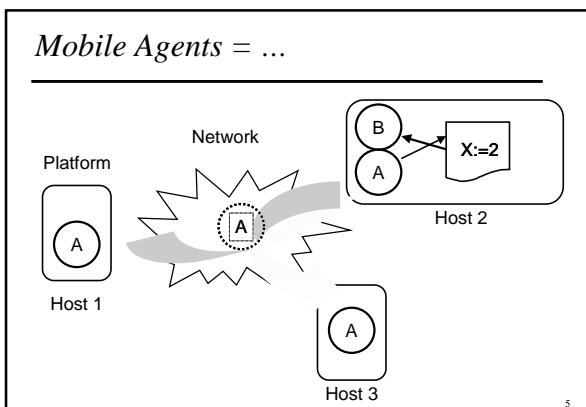

Mobile Agents: Applications Domains

▶ Network Management	▶ Active Documents
▶ Remote Device Control and Configuration	▶ Workflow Management
▶ Active Networks	▶ Grid Computing and Global Computing
▶ Wireless Applications	▶ Emerging <ul style="list-style-type: none"> • IP telephony, service composition
▶ E-commerce, M-commerce	▶ ... and Fault-Tolerance!
▶ Distributed Information Retrieval	

6

Fault-Tolerance and Mobile Agents

Abnormal Situations

- Underlying components failures
 - Platform: memory, disk usage, unavailable resources
 - Network: communication delays, node crashes, disconnection
 - ☞ Tolerated by underlying support
- Partner's errors
 - Impossibility of interaction, failures
 - ☞ Co-operative resolution
- Agents own faults
 - ☞ Local resolution

7

Fault-Tolerance and Mobile Agents

Mobile Agents Requirements

- Recovery from errors at remote locations
- Light recovery code
- Impossible to maintain checkpoints (backward error recovery)
- Mobile agents cannot stay in transactions
- Unanticipated abnormal situations
- Unknown locations of mobile agents

☞ Fault-tolerance at the application level

☞ Forward-error recovery

8

Fault-Tolerance and Mobile Agents

Evaluation Criteria

- Structuring Fault Tolerance (Built-in/Separated)
- Error processing/Error Confinement
- Recursive Structuring and Scalability
- Overheads
- Flexibility, Run-time reconfigurability

9

Example

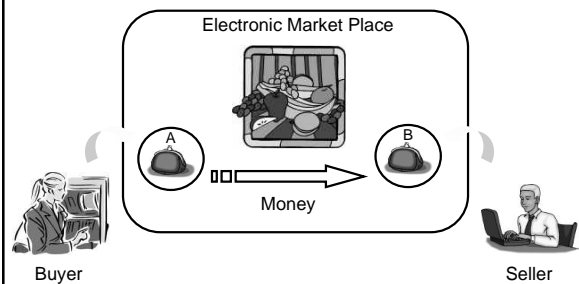

10

Fault-Tolerance Techniques

- Meta-Agent
- Coordinated Atomic Actions
- Asynchronous Resolution
- Self-Repair
- Proof Carrying Code

11

Meta-Agent

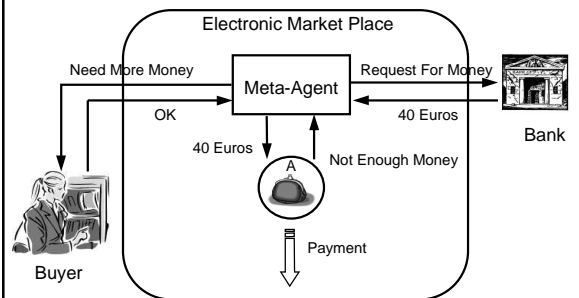

12

Meta-Agent

- Characteristics**
 - Error handling code downloaded at run-time
 - Several exception handlers available simultaneously
 - No overhead in the agent code size
- Good for ...**
 - Asynchronous recovery from local errors
 - No need for a co-operative resolution scheme
- Application domains**
 - Wireless applications
 - Active networks

13

Coordinated Atomic Actions

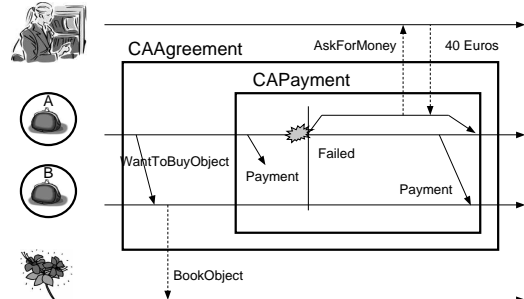

14

Coordinated Atomic Actions

- Characteristics**
 - Define damage area (CA action)
 - Recursive System Structuring
- Good for ...**
 - Complex applications involving co-operating agents
 - Need for co-operative handling of exceptions
- Application domains**
 - Active documents
 - Workflow management applications

15

Asynchronous Resolution

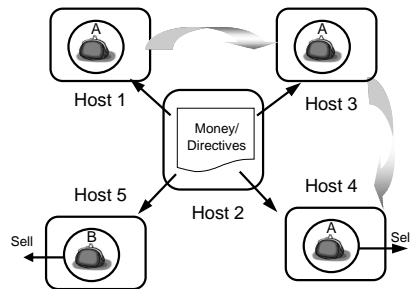

16

Asynchronous Resolution

- Characteristics**
 - Scales to large-size systems
 - Combined with meta-agents
 - increased flexibility
 - overhead
- Good for ...**
 - Asynchronous recovery
 - Collaborative agents
 - can be individually recovered from same exception
 - in their particular location
- Application domains**
 - Grid computing
 - E-commerce, M-commerce

17

Self-Repair

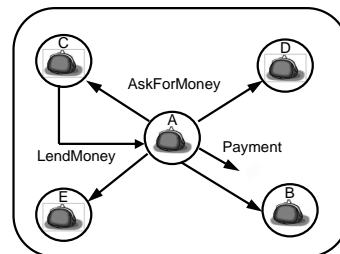

18

Self-Repair

Characteristics

- Scales to large-size systems
- Error confined in the agent
- Overhead in the code size
- May employ meta-agents

Good for ...

- Agent having full autonomy
- Agent needs to recover even partially
- Decentralised control for functionality and fault-tolerance
- Situations requiring quick resolution

Application domains

- Wireless applications
- Remote device control
- Active Networks

19

Proof Carrying Code

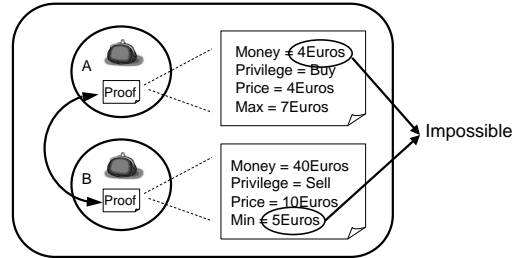

20

Proof Carrying Code

Characteristics

- Proof is part of the agent, not customizable
- Limited flexibility for recovering unanticipated errors
- Overhead of code size and execution time to execute the proof

Good for ...

- Agents interacting with unknown agents, or ...
- ... agents using different standards

Application domains

- Service discovery and composition at run-time

21

Conclusion

Mobile Agent Systems

- Specific characteristics: decentralised, dynamic, roaming entities
- Specific abnormal situations: migration errors, resources and security problems, partner's failures
- Investigation of new techniques for fault-tolerance at: application level + forward error recovery

Application to:

- biologically inspired systems
- portable devices applications (physical mobility)

22