

Axiomatizability of reducts of algebras of relations

IAN HODKINSON*
Department of Computing
Imperial College, London
imh@doc.ic.ac.uk

SZABOLCS MIKULÁS†
Department of Computer Science
King's College London
szabolcs@dcs.kcl.ac.uk

Abstract

In this paper, we prove that any subreduct of the class of representable relation algebras whose similarity type includes intersection, relation composition and converse is a non-finitely axiomatizable quasivariety and that its equational theory is not finitely based. We show the same result for subreducts of the class of representable cylindric algebras of dimension at least three whose similarity types include intersection and cylindrifications. A similar result is proved for subreducts of the class of representable sequential algebras.

1 Introduction

The aim of this paper is to investigate algebras of relations from the finite axiomatizability point of view. In algebraic logic, the most extensively investigated classes of algebras of relations are the class of (representable) relation algebras and the class of (representable) cylindric algebras, cf. [HMT]. These classes are Boolean algebras equipped with some extra-Boolean operations arising from the nature of relations. In this paper we concentrate on subreducts of these classes, i.e., on classes of algebras whose similarity types may not contain all the operations available in relation and cylindric algebras. We will deal with algebras with lower semilattice reducts instead of the whole Boolean structure, and show that the interaction of intersection (the representation of meet) and some extra-Boolean operations is already complex enough to cause non-finite axiomatizability.

Although our non-finite axiomatizability results in this paper do have a negative character, none the less there is profit to be had in taking reducts of the classical algebras of relations to smaller signatures. Andréka [And90] has shown that the equational theory of many positive reducts of representable algebras is decidable. Perhaps the more limited expressive power of these algebras is also reflected in simpler inference systems for these equational theories. Studying reducts may also help to advance the currently active programme of research into the ‘dynamic paradigm’ in computer science, one aim of which is to select only those operations that are relevant to the intended applications. See [Ben96], for example.

Relation algebras: Monk showed in [Mon64] that the variety RRA of representable relation algebras is not finitely axiomatizable. Several authors have investigated whether this negative result holds for various subreducts of RRA (see the formal definition of subreduct in Definition 2.1 below).

For instance, Andréka showed that any subreduct of RRA whose operations include union, intersection and composition is not finitely axiomatizable [And91], and that the {union, composition}-subreduct is a non-finitely axiomatizable quasivariety [And88]. Bredikhin [Bre77] showed that the {composition, converse}-subreduct is not finitely axiomatizable either.

On the other hand, some subreducts are finitely axiomatizable. For instance, Bredikhin and Schein [BS78] showed that the {intersection, composition}-subreduct coincides with the class of

*Partially supported by EPSRC No. GR/L85978.

†Supported by EPSRC No. GR/L82441 and OTKA No. T30314.

semilattice-ordered semigroups. Another example is the generalized subreduct with the similarity type of intersection, composition and its two residuals: see [AM94]. See also [Bre93] about the axiomatizability of the equational theories of reducts of RRA.

In this paper, we give a relatively simple proof that any generalized subreduct of RRA in which intersection, composition and converse are term definable is not finitely axiomatizable (Theorem 2.3). We note that the non-finite axiomatizability of the {intersection, composition, converse}-subreduct of RRA follows from [Hai91] (although this is not stated in that paper).

Another non-finitely axiomatizable version of algebras of binary relations is the class of representable sequential algebras; see, e.g., [Kar94, JM97]. As a corollary, we obtain that the union-free subreduct of representable sequential algebras is not finitely axiomatizable either (Corollary 2.5).

Cylindric algebras: Monk [Mon69] showed that the variety RCA_α of α -dimensional representable cylindric algebras is not finitely axiomatizable either, if α is at least three. Finite axiomatizability of subreducts of RCA_α has been investigated, cf. [Com91] and [Han95]. See also [Dün93] for lattice-reducts of cylindric algebras and their connections to databases. The problem whether intersection and cylindrifications are finitely axiomatizable remained open. Here we answer the question negatively: see Corollary 2.8.

Techniques: We use games and colored graphs. Recently, Hirsch and Hodkinson have applied a game-theoretic approach to various problems concerning relation algebras [HH97, HH97a, HH97b]. For instance, representability of algebras can be characterized by the existence of winning strategies in certain two-player games. Representability can also be approximated in this way, allowing us to prove non-finite axiomatizability. Note that games can also be used to obtain (infinite) recursive axiomatizations of our classes of algebras, by describing the existence of a winning strategy in first-order logic; we will not pursue this here, but see [HH97] for how it works. Similar techniques were used in [Jón59] to axiomatize the {intersection, composition, converse, identity}-subreduct of RRA. Using graph colorings to prove non-finite axiomatizability is a standard technique in algebraic logic — see, e.g., [HMT].

In this paper, we will use colored graphs to define non-representable algebras and games to prove the representability of their ultraproducts. Usually, graph-coloring techniques assume that Boolean join is an available operation to ensure that every sequence in the representation has a (unique) color. In our case, only Boolean meet is included into the similarity type, so the construction is more delicate.

2 Basic definitions and main results

In this section we recall the basic definitions and formulate our main results. We will give short proofs using some lemmas whose proofs are postponed to the subsequent sections.

First we define (generalized sub)reducts of (classes of) algebras.

Definition 2.1 *Let $\mathfrak{A} = (A, o)_{o \in \tau}$ be an algebra of the similarity type τ . Let τ' be a set of operations whose elements are definable by fixed terms in τ . By the τ' -reduct of \mathfrak{A} we mean the algebra $\mathfrak{Rd}_{\tau'}\mathfrak{A} = (A, o)_{o \in \tau'}$. We call $\mathfrak{Rd}_{\tau'}\mathfrak{A}$ a generalized reduct of \mathfrak{A} , since τ' may not be a subset of τ .*

If \mathbf{K} is a class of algebras of the same similarity type, $\mathbf{Rd}_{\tau'}\mathbf{K}$ denotes the class of τ' -reducts of elements of \mathbf{K} . The τ' -subreduct of \mathbf{K} is defined as $\mathbf{SRd}_{\tau'}\mathbf{K}$: i.e., we close $\mathbf{Rd}_{\tau'}\mathbf{K}$ under (isomorphic copies of) subalgebras. Again, we call $\mathbf{SRd}_{\tau'}\mathbf{K}$ a generalized subreduct of \mathbf{K} .

Next we recall the definition of (representable) relation algebras.

Definition 2.2 1. A relation algebra, an RA, is an algebra

$$\mathfrak{A} = (A, 0, 1, \cdot, +, -, ;, \smile, 1')$$

such that $(A, 0, 1, \cdot, +, -)$ is a Boolean algebra, and the following equations hold, for every $x, y, z \in A$:

$$(R1) \ x ; (y ; z) = (x ; y) ; z$$

$$(R2) \ (x + y) ; z = (x ; z) + (y ; z)$$

$$(R3) \ x ; 1' = x$$

$$(R4) \ x^{\smile} = x$$

$$(R5) \ (x + y)^{\smile} = x^{\smile} + y^{\smile}$$

$$(R6) \ (x ; y)^{\smile} = y^{\smile} ; x^{\smile}$$

$$(R7) \ x^{\smile} ; -(x ; y) \leq -y.$$

We denote the class of all relation algebras by RA.

2. By a relation set algebra, an Rs, we mean an algebra $\mathfrak{A} = (A, 0, 1, \cdot, +, -, ;, \smile, 1')$ such that $A \subseteq \mathcal{P}(W)$ (the powerset of W) for some set W of the form $U \times U$, $0 = \emptyset$, $1 = W$, \cdot is intersection, $+$ is union, $-$ is complement w.r.t. W , $;$ is relation composition, \smile is relation converse, and $1'$ is the identity relation on U . More formally, for all elements $x, y \in A$,

$$\begin{aligned} x ; y &= \{(u, v) \in W : (u, w) \in x \text{ and } (w, v) \in y \text{ for some } w\} \\ x^{\smile} &= \{(u, v) \in W : (v, u) \in x\} \\ 1' &= \{(u, v) \in W : u = v\}. \end{aligned}$$

We denote the class of relation set algebras by Rs.¹ Given an $\mathfrak{A} \in \text{Rs}$, W and U as above, we call W the unit of \mathfrak{A} and U the base of \mathfrak{A} .

The class RRA of representable relation algebras is defined as

$$\text{RRA} = \text{SPRs}$$

— i.e., we close the class Rs under products and isomorphic copies of subalgebras.

It is well known that RRA is a variety, and hence a quasivariety. It follows that any generalized subreduct of RRA is a quasivariety:

$$\text{SRd}_{\tau'}\text{RRA} = \text{SRd}_{\tau'}\text{PUpRRA} = \text{SPUpRd}_{\tau'}\text{RRA}.$$

The same observations hold for RCA_{α} (see below) in place of RRA.

Our first main result concerns the finite axiomatizability of such quasivarieties.

Theorem 2.3 *Let \mathbf{K} be a generalized subreduct of RRA such that intersection, relation composition, and converse are term definable in \mathbf{K} . Then*

1. \mathbf{K} is not axiomatizable by any finite set of first-order sentences and
2. the equational theory of \mathbf{K} is not finitely based.

Proof: We will define finite, integral and symmetric relation algebras \mathfrak{A}_n ($n \in \omega$) and show that their $\{\cdot, ;, \smile\}$ -reducts are not representable (Lemma 3.1), while a non-trivial ultraproduct of them is representable (Lemma 3.4). By Łoś' theorem [Hod93, Theorem 9.5.1], this is enough to show that \mathbf{K} is not finitely axiomatizable in first-order logic. Further, we will show that, for all finite n , there is a valid equation that fails in \mathfrak{A}_n (Lemma 3.1), establishing that the equational theory is not finitely axiomatizable either. ■

Our next aim is to show a corollary about non-finite axiomatizability of representable sequential algebras.

¹We will also consider set algebras of relations in smaller signatures than this, but by default the signature will be as above.

Definition 2.4 An algebra $\mathfrak{A} = (A, 0, 1, \cdot, +, -, ;, \triangleleft, \triangleright, 1')$ is a representable sequential algebra, if

- $(A, 0, 1, \cdot, +, -)$ is a Boolean set algebra with unit W for some transitive and reflexive relation W on some set U ,
- $;$ is relation composition,
- $1'$ is the identity relation on U ,
- and for all $x, y \in A$,

$$\begin{aligned} x \triangleright y &= \{(u, v) \in W : (w, u) \in x, (w, v) \in y \text{ for some } w\} \\ x \triangleleft y &= \{(u, v) \in W : (v, w) \in y, (u, w) \in x \text{ for some } w\}. \end{aligned}$$

The class of representable sequential algebras is a variety, [JM97], but it is not finitely axiomatizable (a result of Andr eka and van Karger, [Kar94]). We show that non-finite axiomatizability holds already for a fragment of the language.

Corollary 2.5 The $\{\cdot, ;, 1', \triangleright\}$ -subreduct of the class of representable sequential algebras is not finitely axiomatizable.

Proof: We show that the $\{\cdot, ;, 1', \triangleright\}$ -reducts of the non-representable relation algebras \mathfrak{A}_n ($n \in \omega$) from the proof of Theorem 2.3 are not representable. Here, we define $x \triangleright y$ as $x \smile ; y$ and $x \triangleleft y$ as $x ; y \smile$. Note that for every $x \in A_n$, $x = x \smile = x \smile ; 1' = x \triangleright 1'$.

Now assume that there is an isomorphism h from $(A_n, \cdot, ;, 1', \triangleright)$ into the $\{\cdot, ;, 1', \triangleright\}$ -reduct of a representable sequential algebra with unit W (for some transitive and reflexive W). Since $x = x \triangleright 1'$ for every x , if $(u, v) \in h(x)$, then $(v, u) \in h(x)$. Now if we define $x \smile$ as $x \triangleright 1'$, we get a representation for $(A_n, \cdot, ;, \smile)$ as well — a contradiction.

On the other hand, the sequential-reduct of the ultraproduct of \mathfrak{A}_n ($n \in \omega$) is representable, since $x \triangleright y$ and $x \triangleleft y$ are definable as $x \smile ; y$ and $x ; y \smile$, respectively. ■

Next we recall the definition of (representable) cylindric algebras.

Definition 2.6 Let α be a finite ordinal.²

1. A cylindric algebra of dimension α , a CA_α , is an algebra

$$\mathfrak{A} = (A, 0, 1, \cdot, +, -, c_i, d_{ij})_{i, j < \alpha}$$

such that $(A, 0, 1, \cdot, +, -)$ is a Boolean algebra, and the following equations hold, for every $x, y \in A$ and $i, j, k < \alpha$:

$$(C1) \ c_i(x + y) = c_i x + c_i y$$

$$(C2) \ x \leq c_i x$$

$$(C3) \ c_i - c_i x = -c_i x$$

$$(C4) \ c_i c_j x = c_j c_i x$$

$$(C5) \ d_{ii} = 1 \text{ and } d_{ij} = d_{ji}$$

$$(C6) \ d_{ik} = c_j(d_{ij} \cdot d_{jk}) \text{ if } j \notin \{i, k\}$$

$$(C7) \ d_{ij} \cdot c_i(d_{ij} \cdot x) \leq x.$$

We denote the class of all cylindric algebras of dimension α by CA_α .

²We will use the convention that $\alpha = \{0, 1, \dots, \alpha - 1\}$.

2. By a cylindric set algebra of dimension α , a Cs_α , we mean an algebra $\mathfrak{A} = (A, 0, 1, \cdot, +, -, \mathbf{c}_i, \mathbf{d}_{ij})_{i,j < \alpha}$ such that $A \subset \mathcal{P}({}^\alpha U)$ for some base set U , $0 = \emptyset$, $1 = {}^\alpha U$, \cdot is intersection, $+$ is union, $-$ is complement w.r.t. ${}^\alpha U$, \mathbf{c}_i is the i th cylindrification, and \mathbf{d}_{ij} is the diagonal element identifying the i th and j th coordinates. That is, the unit ${}^\alpha U$ of a Cs_α is the set of α -long sequences of elements of U , and the extra-Boolean operations have the following interpretations. Let $s \equiv_i t$ iff $(\forall j \neq i) s(j) = t(j)$. Then, for each element $x \in A$ and $i, j < \alpha$,

$$\begin{aligned} \mathbf{c}_i x &= \{s \in {}^\alpha U : s \equiv_i t \text{ for some } t \in x\} \\ \mathbf{d}_{ij} &= \{s \in {}^\alpha U : s(i) = s(j)\}. \end{aligned}$$

The class RCA_α of representable cylindric algebras of dimension α is defined as

$$\text{RCA}_\alpha = \text{SPCs}_\alpha,$$

i.e., we close the class Cs_α under products and isomorphic copies of subalgebras.

We define the operation *substitution* \mathbf{s}_j^i as follows:

$$\mathbf{s}_j^i x = \begin{cases} \mathbf{c}_i(x \cdot \mathbf{d}_{ij}) & \text{if } i \neq j \\ x & \text{if } i = j. \end{cases}$$

Note that, in a cylindric set algebra with base U ,

$$\mathbf{s}_j^i x = \{s \in {}^\alpha U : s \equiv_i t \text{ for some } t \in x \text{ such that } t(i) = t(j)\}$$

for distinct i, j .

Our main result about cylindric algebras is Corollary 2.8 below. First we state an apparently weaker theorem.

Theorem 2.7 *Let $\alpha \geq 3$ be finite and let \mathbf{K} be a generalized subreduct of RCA_α such that intersection, cylindrifications and substitutions are term definable in \mathbf{K} . Then*

1. \mathbf{K} is not finitely axiomatizable by first-order sentences and
2. the equational theory of \mathbf{K} is not finitely based.

Proof: Let the dimension set $\alpha \geq 3$ be fixed. First we will define a class of colored graphs. Using these graphs we will define finite cylindric algebras: roughly speaking, an atom will be a surjective map from α to a graph. We will show in Lemma 4.3 that the {intersection, cylindrifications, substitutions}-reducts of these algebras are not representable, and similarly to the RA-case, one can construct valid equations witnessing the non-representability of these algebras. On the other hand, using games will show in Lemma 4.6 that any non-trivial ultraproduct of the algebras is a representable cylindric algebra. ■

Finally, we formulate the stronger result about cylindric algebras.

Corollary 2.8 *The {intersection, cylindrifications}-subreduct of RCA_α (for finite $\alpha \geq 3$) is not finitely axiomatizable.*

We will show how to prove the above corollary at the end of Section 4.

3 Relation algebras

This section is devoted to making the proof of Theorem 2.3 complete.

3.1 The rainbow construction

First we define relation algebras \mathfrak{A}_n ($n \in \omega$), and show that their $\{\cdot, ;, \smile\}$ -reduct is not representable.

Let n be any natural number. We define \mathfrak{A}_n to be the finite relation algebra (in RA) with the following atoms:

- identity: $1'$,
- greens: \mathbf{g}_i ($0 \leq i \leq 2^n$),
- whites: $\mathbf{w}, \mathbf{w}_{ij}$ ($0 \leq i < j < 2^n$),
- yellow: \mathbf{y} ,
- black: \mathbf{b} ,
- reds: \mathbf{r}_i ($0 < i < 2^n$).

All the atoms are self-converse. Given this, a triple (x, y, z) of atoms is said to be an *inconsistent triangle* if $x \cdot (y; z) = y \cdot (z; x) = z \cdot (x; y) = 0$. Conversely, using additivity, composition is determined by the set of inconsistent triangles. We will define composition by specifying that the inconsistent triangles are precisely the following:

$$\begin{aligned} &(\text{green, green, green}) \\ &(\text{yellow, yellow, yellow}) \\ &(\text{green, green, white}) \\ &(\text{yellow, yellow, black}) \\ &(\mathbf{r}_i, \mathbf{r}_j, \mathbf{r}_k) \quad \text{unless } i + j = k \text{ or } i + k = j \text{ or } j + k = i \\ &(\mathbf{g}_i, \mathbf{g}_{i+1}, \mathbf{r}_j) \quad \text{unless } j = 1 \\ &(\mathbf{g}_i, \mathbf{y}, \mathbf{w}_{jk}) \quad \text{unless } i \in \{j, k\}, \end{aligned}$$

where, e.g., (green, green, white) stands for: $g; g' \cdot w = g; w \cdot g' = w; g \cdot g' = 0$ for all green atoms g, g' and any white atom w . We also require that $(x, y, 1')$ is inconsistent for all distinct atoms x, y .

It is not difficult to check that \mathfrak{A}_n is a relation algebra. In fact, all the axioms but (R1) are straightforward to check. An easy way to prove that (R1) is satisfied as well is to show that the existential player can survive one round in the game played using atomic networks on \mathfrak{A}_n (see Definition 3.2, and cf. [Lyn50, pp. 711-712]), and Claim 3.5 below shows that she can do this.

Next we show that the $\{\cdot, ;, \smile\}$ -reduct \mathfrak{B}_n of \mathfrak{A}_n is not representable as a set algebra of binary relations.

Lemma 3.1 *For any $n \in \omega$, \mathfrak{A}_n is not in RRA. In fact, the $\{\cdot, ;, \smile\}$ -reduct \mathfrak{B}_n of \mathfrak{A}_n is not representable either. Moreover, for every $n \in \omega$, there is an equation valid in set algebras that fails in \mathfrak{B}_n .*

Proof: Towards a contradiction, let us assume that there is an isomorphism h from \mathfrak{B}_n to a set algebra of relations of similarity type $\{\cdot, ;, \smile\}$. We let 0 denote the zero element of \mathfrak{A}_n ; of course, as 0 is not in the signature of \mathfrak{B}_n , we may have $h(0) \neq \emptyset$.

Since $\mathbf{w} \not\leq 0$, there is $(u, v) \in h(\mathbf{w})$ such that $(u, v) \notin h(0)$. Because $\mathbf{w} \leq \mathbf{g}_i; \mathbf{y}$, we see that, for every $0 \leq i < 2^n$, there exists u_i such that $(u, u_i) \in h(\mathbf{g}_i)$ and $(u_i, v) \in h(\mathbf{y})$. Since $\mathbf{g}_i \smile = \mathbf{g}_i$ in \mathfrak{B}_n , $(u_i, u) \in h(\mathbf{g}_i)$, and similarly, $(v, u_i) \in h(\mathbf{y})$.

Now $(u_i, u_{i+1}) \in h(\mathbf{g}_i; \mathbf{g}_{i+1} \cdot \mathbf{y}; \mathbf{y}) = h(\mathbf{r}_1)$ for every $0 \leq i < 2^n$. By $\mathbf{g}_i; \mathbf{g}_{i+2} \cdot \mathbf{y}; \mathbf{y} \cdot \mathbf{r}_1; \mathbf{r}_1 = \mathbf{r}_2$, for every $i < 2^n - 1$, $(u_i, u_{i+2}) \in h(\mathbf{r}_2)$. In particular, $(u_0, u_2) \in h(\mathbf{r}_2)$ and $(u_{2^n-2}, u_{2^n}) \in h(\mathbf{r}_2)$. By induction, we get that $(u_0, u_{2^n-1}) \in h(\mathbf{r}_{2^n-1})$ and $(u_{2^n-1}, u_{2^n}) \in h(\mathbf{r}_{2^n-1})$. Then we have $(u_0, u_{2^n}) \in h(\mathbf{g}_0; \mathbf{g}_{2^n} \cdot \mathbf{y}; \mathbf{y} \cdot \mathbf{r}_{2^n-1}; \mathbf{r}_{2^n-1}) = h(0)$. Since $(u, u_0) \in h(\mathbf{g}_0)$ and $(u_{2^n}, v) \in h(\mathbf{y})$, we get that $(u, v) \in h(\mathbf{g}_0; 0; \mathbf{y}) = h(0)$. But we assumed that $(u, v) \notin h(0)$. We have our contradiction. See Figure 1 for a sketch of the argument.

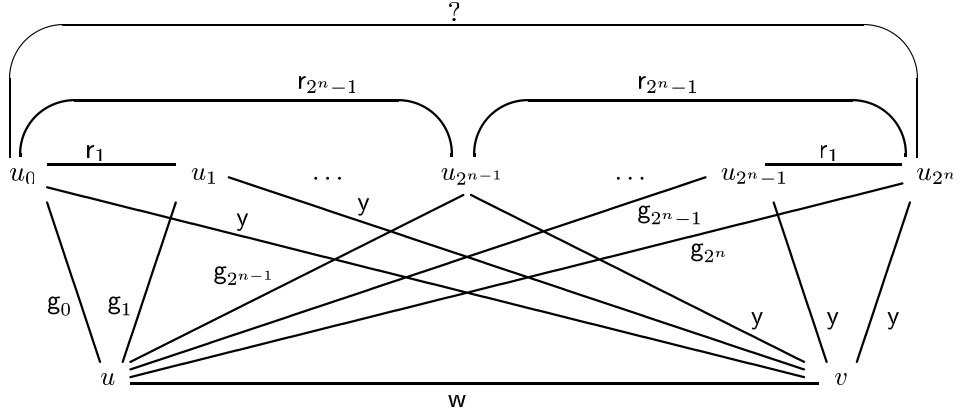

Figure 1: The reason for non-representability

The non-representability of \mathfrak{B}_n is witnessed by the following equation. For $0 \leq i < j \leq 2^n$, let $\rho_{i,j}$ stand for $\mathbf{g}_i; \mathbf{g}_j \cdot \mathbf{y}; \mathbf{y}$. We define $\rho(k, k + 2^l)$, for each $0 \leq k < k + 2^l \leq 2^n$, by induction on l :

$$\begin{aligned} \rho(k, k + 1) &= \rho_{k, k+1} \\ \rho(k, k + 2^{l+1}) &= \rho(k, k + 2^l); \rho(k + 2^l, k + 2^{l+1}) \cdot \rho_{k, k+2^{l+1}}. \end{aligned}$$

Let σ_n be $\mathbf{w} \cdot \prod \{(\mathbf{g}_i \cdot \mathbf{g}_i^\smile); (\mathbf{y} \cdot \mathbf{y}^\smile) : 0 \leq i \leq 2^n\}$ and τ_n equal $\mathbf{w} \cdot \mathbf{g}_0; \rho(0, 2^n); \mathbf{y}$. The equation e_n is defined as the result of replacing atoms by distinct variables in $\sigma_n = \sigma_n \cdot \tau_n$. It is easy to check that e_n is valid in set algebras. On the other hand, the argument we used above to prove that \mathfrak{B}_n is not representable shows that e_n fails in \mathfrak{B}_n . ■

It remains to show that any non-trivial ultraproduct of the \mathfrak{A}_n ($n \in \omega$) is representable.

3.2 The game

We recall from [HH97b] the definition of a game connected to representability.

Definition 3.2 *Let \mathfrak{A} be a relation-type algebra.*

1. A pre-network is a complete directed finite graph with edges labeled by elements of \mathfrak{A} : i.e., $N = (E_N, \ell_N)$, where $E_N = U_N \times U_N$ for some finite non-empty set U_N , the base of N , and $\ell_N : E_N \rightarrow \mathfrak{A}$ is a map assigning an element of \mathfrak{A} to each edge.

A pre-network is a network if it also satisfies, for every $x, y, z \in U_N$,

- (a) $\ell_N(x, y) \leq 1'$ iff $x = y$,
- (b) $\ell_N(x, y); \ell_N(y, z) \cdot \ell_N(x, z) \neq 0$.

A pre-network is called atomic if all the edges are labeled by atoms of \mathfrak{A} . If no confusion is likely, we will omit the subscript N .

Given two pre-networks N, N' , we write $N \subseteq N'$ if every edge of N is an edge of N' and, for every edge (x, y) of N , $\ell_{N'}(x, y) \leq \ell_N(x, y)$.

2. Let $n \in \omega$. We define a game $G_n(\mathfrak{A})$ between two players, \forall (male), and \exists (female). They build a finite chain $N_0 \subseteq N_1 \subseteq \dots \subseteq N_n$ of pre-networks in the following way. N_0 is any consistent triangle, i.e., a network such that $|U_{N_0}| \leq 3$. We regard N_0 as being chosen by \forall before the game starts. In each round i ($0 \leq i < n$),

- \forall chooses an edge (x, y) from N_i and elements $r, s \in A$,

- \exists responds with a pre-network $N_{i+1} \supseteq N_i$ such that one of the following holds:
 - \exists rejects: N_{i+1} is the same as N_i except that $\ell_{N_{i+1}}(x, y) = \ell_{N_i}(x, y) \cdot -(r; s)$,
 - \exists accepts: the nodes of N_{i+1} are those of N_i , plus a possibly new one, z , and the labels on edges of N_{i+1} satisfy the following:
 - $\ell_{N_{i+1}}(x, z) = r$,
 - $\ell_{N_{i+1}}(z, y) = s$,
 - $\ell_{N_{i+1}}(x, y) = \ell_{N_i}(x, y) \cdot r; s$.

\exists wins a match of the game $G_n(\mathfrak{A})$ if every N_i ($0 \leq i \leq n$) is a network. We say that \exists has a winning strategy if she can win all matches.

The atomic game $G_n^a(\mathfrak{A})$ is defined by requiring that all the elements r, s chosen by \forall are atoms, and that each N_i is an atomic pre-network.

The following proposition [HH97b, Proposition 15] provides us with a sufficient condition for representability of atomic relation algebras.

Proposition 3.3 *Let \mathfrak{A} be an atomic relation algebra. Then \exists has a winning strategy in $G_n^a(\mathfrak{A})$ for all $n \in \omega$ iff \mathfrak{A} is elementarily equivalent to a completely representable relation algebra.³ Hence, because RRA is elementary, if \exists has a winning strategy in $G_n^a(\mathfrak{A})$ for all $n \in \omega$, then \mathfrak{A} is representable.*

3.3 The ultraproduct

We will now show that an ultraproduct of the \mathfrak{A}_n ($n \in \omega$) is representable.

Lemma 3.4 *Any non-trivial ultraproduct \mathfrak{A} of \mathfrak{A}_n ($n \in \omega$) over ω is in RRA. Hence the ultraproduct of the $\{\cdot, ;, \smile\}$ -reducts of \mathfrak{A}_n ($n \in \omega$) is representable as well.*

Proof: First we show that \exists can survive arbitrarily long games on a “large” set (occurring in the ultrafilter) of algebras. The “ultraproduct” of these strategies will enable her to win arbitrarily long (in fact, ω -long) games on the ultraproduct. Thus, by Proposition 3.3, the ultraproduct will be representable.

Claim 3.5 *Let $l \in \omega$. \exists has a winning strategy for $G_l^a(\mathfrak{A}_n)$ for cofinitely many algebras \mathfrak{A}_n ($n \in \omega$).*

Proof: Let n be large enough — say, $n \geq l$. We show that \exists can win $G_l^a(\mathfrak{A}_n)$.

The idea is very roughly that \forall 's best strategy leads to what is in effect a new game, played on two irreflexive linear orders. One consists of the indices of green atoms and is of length $2^l + 1$; the other is of length 2^l , and the intervals in it correspond to indices of red atoms. In each round, \forall chooses an element of the first, longer order, and \exists must respond by choosing an element of the other. For her to win, the choices made during the game must induce a partial isomorphism (an order-preserving partial map) between the orders. As \forall 's linear order is longer than \exists 's, he can certainly win if he is given enough time. However, the game here is of length at most $l - 1$, and this does not quite leave him sufficient time to expose the difference in length of the orders.

We now proceed to the formal proof. Let us assume that we are in the p th ($0 \leq p < l$) round and that an atomic network $N_p = (U_{N_p} \times U_{N_p}, \ell_{N_p})$ is already constructed.

We define the important notion of a *red block*. Suppose that u, v are distinct nodes of N_p and that $\ell_{N_p}(u, v) \neq w_{ij}$ for any i, j . Let

$$W = \{w : w \text{ a node of } N_p, \ell_{N_p}(u, w) \text{ is green, and } \ell_{N_p}(v, w) = y\}.$$

³A complete representation of a relation algebra \mathfrak{B} is an isomorphism from \mathfrak{B} to a representable relation algebra that preserves arbitrary meets and joins whenever they exist in \mathfrak{B} . However, we will not need this notion in this paper.

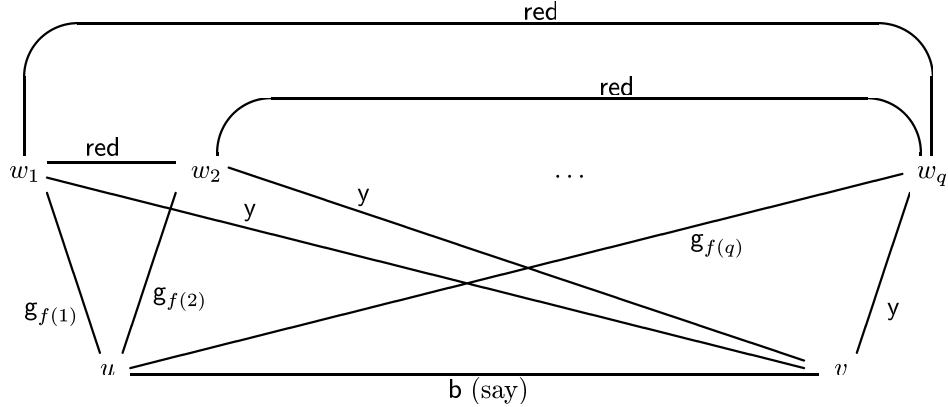

Figure 2: A red block $(u, v, w_1, w_2, \dots, w_q)$

Assume that $|W| \geq 2$. Also assume that W can be linearly ordered $(w_1 < \dots < w_q)$ in the following way: the map f from $\{1, \dots, q\}$ into the set $2^l + 1$ of indices of green atoms given by $\ell_{N_p}(u, w_i) = \mathfrak{g}_{f(i)}$ for every $1 \leq i \leq q$, satisfies $f(i) < f(j)$ for every $1 \leq i < j \leq q$. Note that the color of every (w_i, w_j) in N_p must be red.

In such a situation, we will call the subnetwork N' of N_p with base $\{u, v\} \cup W$ a *red block* with *center* (u, v) . See Figure 2. Usually we will denote this red block by the ordered tuple (u, v, w_1, \dots, w_q) . We will say that w_i and w_{i+1} are *neighbors*, and that the *distance* of w_i from w_j is $|f(j) - f(i)|$.

We now state the following induction hypothesis (with p , the round number, as a parameter), that \exists will maintain in each round of the game.

Induction hypothesis: For every red block (u, v, w_1, \dots, w_q) of N_p in the above notation, and for every $1 \leq i < j \leq k \leq q$,

1. $\ell_{N_p}(w_i, w_j) = r_{f(j)-f(i)}$ if $f(j) - f(i) \leq 2^{l-p}$,
2. $\ell_{N_p}(w_i, w_j) = r_t$ for some $t \leq 2^{l-1} + \dots + 2^{l-(j-i)}$,
3. $\ell_{N_p}(w_i, w_j) = r_t$ and $\ell_{N_p}(w_j, w_k) = r_s$ imply $\ell_{N_p}(w_i, w_k) = r_{t+s}$.

Note that $q \leq p + 1$, since $|U_{N_0}| \leq 3$ and, in each round, at most one new point is created. The induction hypothesis now implies that the largest index on a red atom (to label (w_1, w_q)) is at most $2^{l-1} + \dots + 2^{l-p}$. Clearly N_0 satisfies the induction hypothesis.

Let us assume that in the p th round player \forall plays (u, v, y, z) for some edge (u, v) of N_p and atoms y, z of \mathfrak{A}_n and that $\ell_{N_p}(u, v) = x$.

If $x \cdot y; z = 0$, then \exists rejects \forall 's proposal — i.e., she defines $N_{p+1} = N_p$. If $x \leq y; z$ and there is a point w in N_p such that $\ell_{N_p}(u, w) = y$ and $\ell_{N_p}(w, v) = z$, then again \exists lets $N_{p+1} = N_p$. Note that this covers the case when either y or z is the identity $1'$.

Otherwise \exists extends N_p by a new point w and lets $\ell_{N_{p+1}}(u, w) = \ell_{N_{p+1}}(w, u) = y$, $\ell_{N_{p+1}}(w, v) = \ell_{N_{p+1}}(v, w) = z$ and $\ell_{N_{p+1}}(w, w) = 1'$ — note that this is well defined, since $u = v$ implies that $x = 1'$, whence $y = z$. She defines the labels for the remaining edges (w, w') , for $w' \in U_{N_p} \setminus \{u, v\}$, as follows (she will label an edge with the same atom as the atom labelling its converse edge; we will not bother to mention this from now on).

\exists 's strategy is to choose a white w_{ij} whenever it is possible: i.e., if labelling (w, w') by w_{ij} ensures that the triangles (w, w', u) and (w, w', v) , or strictly, the triples consisting of the labels on the edges of these triangles, are consistent in \mathfrak{A}_n . If this fails, she tries to use black, \mathfrak{b} . If this

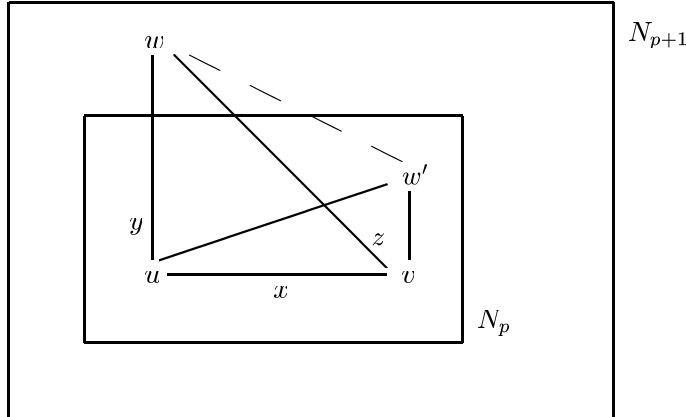

Figure 3: Extending the network

is impossible, too, then she uses a red color r_i . She chooses the index i carefully to maintain the induction hypothesis so that \forall will not be able to create a contradiction during the l rounds of the game. Note that she never chooses a yellow or green label. We have the following cases.

Case 1: $\{y, z\} \neq \{g_i, y\}$ for any i . An easy argument using case distinction shows that, for any w' , \exists can choose $\ell_{N_{p+1}}(w', w)$ to be either w_{jj} ; or, if this creates an inconsistent triangle among (w, w', u) and (w, w', v) , w_{jk} for some distinct j, k ; or if this creates an inconsistent triangle too, **b**. It is easy to check that this yields an atomic network, since no triangle that involves either two white edges, or two black edges, or a white and a black edge, can be inconsistent. Further, no new red block has been created. For, any new red block must contain w and one other point $w' \neq u, v$; since the label on (w, w') is white or black, (w, w') is the center of the new block; because \exists did not use green or yellow labels, the other points of the block are u, v ; hence, y and z are both green and $\ell_{N_p}(u, w')$ and $\ell_{N_p}(v, w')$ are both yellow, or vice versa; but then, \exists would use a w_{ij} to label (w, w') , contradicting the definition of red block. Because a red block has only one edge labeled other than yellow, green, or red, and \exists used only white or black here, it follows that no point has been added to any red block. So the red blocks of N_{p+1} are precisely those of N_p . It can be seen that any red block in N_p that satisfied the inductive hypothesis for p still satisfies it in N_{p+1} for $p + 1$. So N_{p+1} satisfies the induction hypothesis.

Case 2: $y = g_i$ and $z = y$. If $w' \in U_{N_p} \setminus \{u, v\}$ and (u, w') is not green, she can let $\ell_{N_{p+1}}(w', w) = w_{ii}$ provided (w', v) is not green, or $\ell_{N_{p+1}}(w', w) = w_{ij}$ in case (w', v) has color g_j . Otherwise, if (w', v) is not yellow, she plays $\ell_{N_{p+1}}(w', w) = \mathbf{b}$.

The hard case is for those w' such that $\ell_{N_p}(w', v) = y$ and $\ell_{N_p}(u, w') = g_j$ for some j . (We can assume that $i \neq j$, otherwise \exists did not extend N_p .) \exists will label all such edges (w, w') in a co-ordinated fashion. Let

$$W = \{w' : w' \text{ a node of } N_p, (u, w') \text{ is green, and } (w', v) \text{ is yellow}\}.$$

Note that $|W| \leq p + 1$. Let W be enumerated in an order $w_1 < w_2 < \dots < w_q$ so that the map f defined by $\ell_{N_p}(u, w_j) = g_{f(j)}$ satisfies $f(j) \leq f(k)$ whenever $j < k$ (cf. the definition of red block).

We claim that if $|W| \geq 2$, the subnetwork with base $W \cup \{u, v\}$ forms a red block with center (u, v) . We have to show that f is one-one and that $\ell_{N_p}(u, v)$ is not any w_{jk} .

So let $j, k \leq q$ be distinct: we require $f(j) \neq f(k)$. As the game starts with a three-point network and at most one point is added in any round, one of the four points u, v, w_j, w_k was added after the other three. We will show that it was w_j or w_k . Assume for a contradiction that, say, u was added after w_j, w_k , and v . (The case where v was added after w_j, w_k ; u is

similar.) Since \exists never chooses a green atom, $\ell_{N_p}(u, w_j)$ and $\ell_{N_p}(u, w_k)$ were chosen by \forall . Thus, in the round when u was created, he played $(w_j, w_k, \mathbf{g}_{f(j)}, \mathbf{g}_{f(k)})$ (or possibly its mirror image $(w_k, w_j, \mathbf{g}_{f(k)}, \mathbf{g}_{f(j)})$). Since $\ell_{N_p}(v, w_j)$ and $\ell_{N_p}(v, w_k)$ are yellow, $\mathbf{w}_{f(j)f(k)}$ (or $\mathbf{w}_{f(k)f(j)}$) was a possible choice for \exists as a color for (u, v) . Then, according to her strategy, she chose $\mathbf{w}_{f(j)f(k)}$ (or $\mathbf{w}_{f(k)f(j)}$). Now consider the current, p th round again. We assumed that the green \mathbf{g}_i played by \forall in this round is distinct from the greens $\mathbf{g}_{f(j)}, \mathbf{g}_{f(k)}$ on (u, w_j) and (u, w_k) (otherwise \exists did not have to extend N_p). But $(u, v, \mathbf{g}_i, \mathbf{y})$ would have been rejected by \exists (since the triangle $(\mathbf{g}_i, \mathbf{y}, \mathbf{w}_{f(j)f(k)})$ is inconsistent), which is a contradiction.

So without loss of generality we may assume that w_k was added to the network after u, v, w_j . Now let us consider again the round, say round t , when w_k was created. Since \exists never plays green or yellow, the reason for adding w_k to the network was that in round t , \forall played $(u, v, \mathbf{g}_{f(k)}, \mathbf{y})$ or its mirror image, and that, in N_t , there was no point s such that (u, s) has color $\mathbf{g}_{f(k)}$ and (s, v) is yellow (otherwise \exists would not have extended N_t). In particular, taking $s = w_j$, we obtain $f(j) \neq f(k)$, so that f is one-one as required.

Thus, the green colors on (u, w_j) ($1 \leq j \leq q$) are all different. We assumed they are also different from $y = \mathbf{g}_i$. So there are at least three consistent triangles of the form $(\text{green}, \mathbf{y}, N_p(u, v))$, and it follows that $N_p(u, v)$ is not any \mathbf{w}_{jk} . Hence, (u, v, w_1, \dots, w_q) is indeed a red block, as claimed. Clearly, (w_j, w_k) must be red for every distinct $j, k \leq q$.

So the network $\{u, v, w_1, \dots, w_q\}$ must satisfy the induction hypothesis. We claim next that \exists can find appropriate red colors for each (w, w_j) ($1 \leq j \leq q$) such that conditions 1–3 of the induction hypothesis hold (when we replace p by $p+1$).

Indeed, let $w_j \in W$ be such that $|i - f(j)|$ is minimal. If $|i - f(j)| \leq 2^{l-p-1}$, then she lets $\ell_{N_{p+1}}(w_j, w) = \mathbf{r}_{i-f(j)}$. If $|i - f(j)| > 2^{l-p-1}$, then she lets $\ell_{N_{p+1}}(w_j, w) = \mathbf{r}_{2^{l-p-1}}$. \exists labels the other edges (w_k, w) by using a red atom indexed by the sum (if $w_k < w_j$ and $f(j) < i$, or $w_j < w_k$ and $i < f(j)$) or the difference (if $w_j < w_k$ and $f(j) < i$, or $w_k < w_j$ and $i < f(j)$) of the indices of the reds on (w_k, w_j) and (w_j, w) . It can be checked that these red colors exist, and conditions 1–3 above hold for the red block $(u, v, w_1, \dots, w, \dots, w_q)$. This ends our proof of the claim.

It remains to show that the induction hypothesis holds for *any* red block N' of N_{p+1} . First, note that if a red block satisfied the induction hypothesis for p (in the previous round) then it satisfies the induction hypothesis for $p+1$ as well. We make the following observation about “new” red blocks that are not red blocks of N_p (cf. above): \exists plays a red color on an edge (w, w') only if there is an edge (u, v) such that (u, w') is green, (w', v) is yellow, and \forall plays $(u, v, \mathbf{g}_i, \mathbf{y})$ so that \exists is forced to extend the network with w and label (u, w) with \mathbf{g}_i and (w, v) with \mathbf{y} . This implies that if we have a new red block, then its center must be the edge (u, v) played by \forall . Thus, the only possible new red block has one of the following forms:

- $(u, v, w_1, \dots, w, \dots, w_q)$, if (u, v, w_1, \dots, w_q) was a red block in N_p , and if \forall played $(u, v, \mathbf{g}_i, \mathbf{y})$,
- (u, v, w, w') or (u, v, w', w) , if $\ell_{N_p}(u, v) \neq \mathbf{w}_{jk}$ for any j, k , $W = \{w'\}$, and if \forall played $(u, v, \mathbf{g}_i, \mathbf{y})$.

By the coloring defined in the previous paragraph, both types of red block satisfy the induction hypothesis.

It is immediate now that all triangles in N_{p+1} are consistent, so that N_{p+1} is a network. All triangles of N_p are known to be consistent. The remaining triangles are of the form (w, u, w') , (w, v, w') , and (w, w', w'') , for $w', w'' \in U_{N_p} \setminus \{u, v\}$. The first two kinds were all made consistent by \exists 's choice of either white, black, or red to label (w, w') . For the third kind, since two sides (w, w') , (w, w'') were labeled by \exists as above, the only danger is when both of them are red. But in this case, w, w' , and w'' are part of a red block with center (u, v) , and the strategy above guarantees that (w, w', w'') is consistent.

Case 3: $y = \mathbf{y}$ and $z = \mathbf{g}_i$. This case is completely analogous to case 2, and we omit the details.

The largest index on red colors used by \exists so far is at most $2^{l-1} + 2^{l-2} + \dots + 2^{l-p-1} < 2^l$, since, in the k th round, she labeled an edge (w, w') of neighboring points w, w' with \mathbf{r}_j such that

$j < 2^{l-k-1}$. Thus, in the remaining rounds of the game, \forall cannot force her to use a non-existing red r_i ($i > 2^n$). In any red block, if the distance $|f(j) - f(k)|$ between two points w_j and w_k is “small”, i.e., smaller than 2^{l-p-1} , then she used $r_{|f(j)-f(k)|}$ to label (w_j, w_k) . Thus, in the remaining rounds, she has enough indices between 1 and $|f(j) - f(k)|$ to label any edge (w_j, w) and (w, w_k) “inserted” into (w_j, w_k) . This shows that she can survive l rounds without arriving at the impossible task of using a non-existing red color. Claim 3.5 is proved. ■

We now finish the proof of the lemma. Since \exists can survive arbitrarily long games on a large set (i.e., included in the non-principal ultrafilter) of algebras, she can achieve this in the ultraproduct \mathfrak{A} as well. Indeed, the winning strategies in $G_l^a(\mathfrak{A}_n)$ provide her with a winning strategy in $G_l^a(\mathfrak{A})$, as follows. We give an outline only; see [HH97b, Lemma 16] for more details.

Assume that a finite atomic \mathfrak{A} -network N is already defined and \forall plays an edge (x, y) with color a (for some atom $a \in A$) and atoms b, c of \mathfrak{A} . Note that every atom d of the ultraproduct \mathfrak{A} is an equivalence class of an ω -sequence $(d_i : i \in \omega)$, with each d_i an atom of \mathfrak{A}_i . For every $i \in \omega$, one can define a pre-network $N^{(i)}$ in the following way. The base of $N^{(i)}$ is that of N , and the color of every edge of $N^{(i)}$ is an atom d_i of \mathfrak{A}_i such that the color d of this edge in N is the equivalence class of $(d_i : i \in \omega)$. It is easy to check that

$$\{i \in \omega : N^{(i)} \text{ is a network}\}$$

is contained in the ultrafilter.

Now \exists considers those particular matches in the games $G_l^a(\mathfrak{A}_i)$ ($i \in \omega$) where \forall plays $(x, y) \in N^{(i)}$ and $b_i, c_i \in A_i$ such that b, c are the equivalence classes of $(b_i : i \in \omega), (c_i : i \in \omega)$. If the set

$$S_0 = \{i \in \omega : \exists \text{ rejects } \forall\text{'s proposal}\}$$

is in the ultrafilter, then she rejects in the game $G_l^a(\mathfrak{A})$ as well. If the complement $\omega \setminus S_0$ of this set is in the ultrafilter, then she considers two of its subsets: S_1 is the set of those indices where she is not forced to extend the network, and S_2 is the set of those indices where she is forced to extend the network. If S_1 is in the ultrafilter, then she does not have to extend the network N , as in N , there are (x, z) and (z, y) such that $b = \ell_N(x, z)$ and $c = \ell_N(z, y)$. If S_2 is contained in the ultrafilter, then she can extend the network by using the atoms of \mathfrak{A} determined by the equivalence classes of the elements she uses in the games $G_l^a(\mathfrak{A}_n)$. This completes her move in response to \forall in this round. Her move in the next round (and in subsequent rounds) is decided in much the same way, but note that she will be *continuing* with her winning strategy already in progress in the games $G_l^a(\mathfrak{A}_n)$ for a large set (in the ultrafilter) of indices n : either S_0 , S_1 , or S_2 . The (finitely many) algebras with indices not in this set can be discarded. ■

4 Cylindric algebras

In this section we prove the necessary lemmas for Theorem 2.7. These lemmas are the cylindric counterparts of the lemmas for the RA-case. The proofs also use similar ideas, though usually they require more computation. If the transition from RA to CA is obvious, we will omit the technical details.

First we recall that the operation *substitution* s_j^i is defined as follows: for every distinct $i, j < \alpha$, $s_j^i x = c_i(x \cdot d_{ij})$, while $s_i^i x = x$. The operation of *composition* $;$ is defined as

$$x ; y = c_2(s_2^1 c_2 x \cdot s_2^0 c_2 y).$$

4.1 Rainbows and graphs

Let $\alpha \geq 3$ be a fixed natural number. First, for every natural number n , we define a class of colored graphs, from which we will later define the algebras $\mathfrak{C}_n \in \text{CA}_\alpha$. The colors will have a similar role to that in the case of relation algebras. White had two roles, and this is reflected here

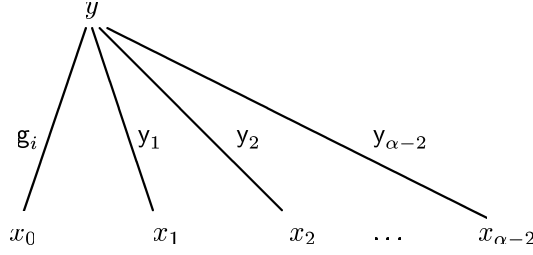

Figure 4: An i -cone

by introducing a new shade of white: ivory. An n -colored graph is an undirected irreflexive graph Γ (i.e., if (u, v) is an edge of Γ then (i) so is (v, u) , and (ii) $u \neq v$), such that every edge of Γ is colored by a unique edge color and some $(\alpha - 1)$ -tuples have a unique color, too. (In the case where $\alpha = 3$, this means that (u, v) can carry both an edge color and a 2-tuple color.) The edge colors are:

- greens: g_i ($0 \leq i \leq 2^n$),
- yellows: y_i ($1 \leq i \leq \alpha - 2$),
- blacks: b_i ($1 \leq i \leq \alpha - 2$),
- reds: r_i ($1 \leq i < 2^n$),
- ivory: i .

The colors for $(\alpha - 1)$ -tuples are:

- whites: w_S ($S \subseteq 2^n + 1$).

We will write $\Gamma(x, y)$ and $\Gamma(a_1, \dots, a_{\alpha-1})$ for the colors of the edge (x, y) and of the $(\alpha - 1)$ -tuple $(a_1, \dots, a_{\alpha-1})$, respectively. This will not cause confusion in the case $\alpha = 3$, since we will always write $\Gamma(a_1, \dots, a_{\alpha-1})$ for the tuple color, with α explicitly mentioned. We usually identify a colored graph with its base (set of nodes), but sometimes we write ‘nodes(Γ)’ for the underlying base.

We define *colored graph embedding* in the obvious way: an injective map from a colored graph into another that preserves all edges and colors, where defined, in both directions.

Definition 4.1 Let $0 \leq i \leq 2^n$ and let Γ be an n -colored graph consisting of α nodes, $x_0, x_1, \dots, x_{\alpha-2}$ and y . We call Γ an i -cone if $\Gamma(x_0, y) = g_i$, and for every $1 \leq j \leq \alpha - 2$, $\Gamma(x_j, y) = y_j$, and no other edge of Γ is colored green or yellow. The apex of the cone is y , its center is the ordered $(\alpha - 1)$ -tuple $(x_0, \dots, x_{\alpha-2})$ and the tint of the cone is i . We will use the notation $(x_0, \dots, x_{\alpha-2}, y)$ for a cone. See Figure 4.

We will consider special n -colored graphs.

Definition 4.2 The class \mathcal{G}_n consists of all n -colored graphs Γ with the following properties.

1. Γ is a complete graph.
2. Γ contains no triangles of the following types (called inconsistent triangles):
 - (green, green, green)
 - (yellow, yellow, yellow)
 - (green, green, ivory)
 - (y_i, y_i, b_i) ($1 \leq i \leq \alpha - 2$)

- (r_i, r_j, r_k) unless $i + j = k$ or $i + k = j$ or $j + k = i$
- (g_i, g_{i+1}, r_j) unless $j = 1$.

3. For every i -cone $(0 \leq i \leq 2^n)$ in Γ with center $(x_0, \dots, x_{\alpha-2})$, the tuple $(x_0, \dots, x_{\alpha-2})$ is colored by a unique shade w_S of white such that $i \in S$.

Clearly, \mathcal{G}_n is closed under isomorphism (denoted as \cong) and under induced subgraphs.

We are ready to define the cylindric algebras \mathfrak{C}_n for every $n \in \omega$. Let

$$K_n = \{a : a \text{ is a surjective map from } \alpha \text{ onto some } \Gamma \in \mathcal{G}_n \text{ with } \text{nodes}(\Gamma) \subseteq \omega\}.$$

Given $a \in K_n$, we will denote by Γ_a that element of \mathcal{G}_n for which $a : \alpha \rightarrow \Gamma_a$. We define an equivalence relation \sim on surjective maps to identify maps with isomorphic ranges. Let $a, b \in K_n$: say, $a : \alpha \rightarrow \Gamma_a$ and $b : \alpha \rightarrow \Gamma_b$. Then

$$\begin{aligned} a \sim b \iff & a(i) = a(j) \text{ iff } b(i) = b(j), \\ & \text{and } \Gamma_a(a(i), a(j)) = \Gamma_b(b(i), b(j)), \text{ if defined,} \\ & \text{and } \Gamma_a(a(k_0), \dots, a(k_{\alpha-2})) = \Gamma_b(b(k_0), \dots, b(k_{\alpha-2})), \text{ if defined,} \end{aligned}$$

for all $i, j, k_0, \dots, k_{\alpha-2} \in \alpha$. It is straightforward to check that \sim is indeed an equivalence relation. Write $[a]$ for the \sim -equivalence class of a :

$$[a] = \{b \in K_n : a \sim b\}.$$

We define $C'_n = \{[a] : a \in K_n\}$. For every $i, j \in \alpha$ and $[a], [b] \in C'_n$, we define $E_{ij} \subseteq C'_n$ and $T_i \subseteq {}^2C'_n$ by:

$$[a] \in E_{ij} \iff a(i) = a(j)$$

and

$$[a]T_i[b] \iff a[(\alpha \setminus \{i\})] \sim b[(\alpha \setminus \{i\})],$$

that is, if the maps a and b restricted to $\alpha \setminus \{i\}$ are equivalent in the sense defined above. We note that

$$[a]T_i[b] \iff \text{for some } c \in [a], b(j) = c(j) \text{ for all } j \neq i.$$

It is not hard to check that the structure $(C'_n, E_{ij}, T_i)_{i, j \in \alpha}$ is a cylindric atom structure, cf. [HMT, 2.7.38, 2.7.40]. We define the cylindric algebra \mathfrak{C}_n as the full complex algebra of $(C'_n, E_{ij}, T_i)_{i, j \in \alpha}$: \mathfrak{C}_n is the full Boolean set algebra with unit C'_n and extra-Boolean operations

$$d_{ij} = E_{ij} = \{[a] : a(i) = a(j)\}$$

and

$$c_i x = \{[b] : \text{for some } [a] \in x, [b]T_i[a]\}.$$

We note that an atom of \mathfrak{C}_n is any $\{[a]\}$ for some map $a \in K_n$. We will call \mathfrak{C}_n the cylindric algebra associated with the class \mathcal{G}_n of graphs.

Next we show that the $\{\text{intersection, cylindrifications, substitutions}\}$ -reduct \mathfrak{B}_n of \mathfrak{C}_n is not representable. The idea of the proof is the same as in the RA-case (Lemma 3.1), though the details are more complicated.

Lemma 4.3 *For any $n \in \omega$, \mathfrak{C}_n is not in RCA_α . Further, its $\{\cdot, c_i, s_j^i : i, j < \alpha\}$ -reduct \mathfrak{B}_n is not representable either.*

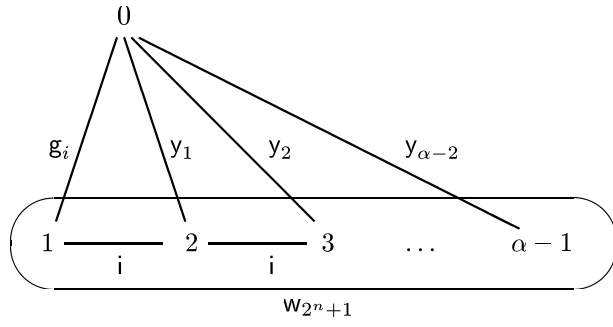

Figure 5: The map $a_i : \alpha \longrightarrow \Gamma_i$

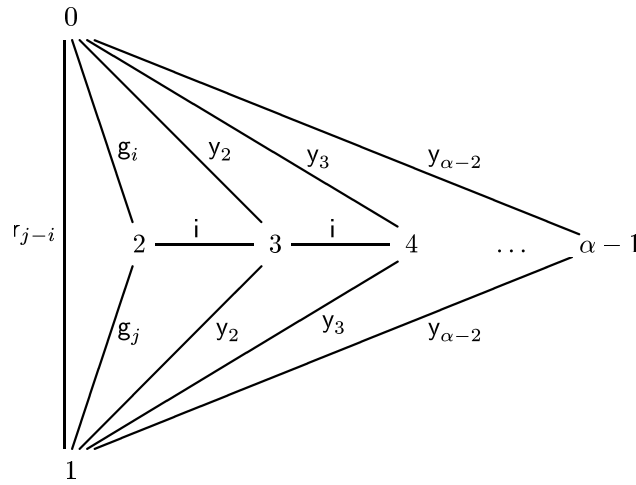

Figure 6: The map $a_j^i : \alpha \longrightarrow \Gamma_j^i$

Proof: To derive a contradiction assume that there is an isomorphism h from \mathfrak{B}_n onto a set algebra of α -ary relations.

Let Γ_i be the following element of \mathcal{G}_n for each $i \leq 2^n$: $\Gamma_i(0,1) = \mathbf{g}_i$, $\Gamma_i(0,j) = \mathbf{y}_{j-1}$ (for $2 \leq j \leq \alpha-1$), $\Gamma_i(j,k) = \mathbf{i}$ (for $1 \leq j < k \leq \alpha-1$) and $\Gamma_i(1,2,\dots,\alpha-1) = \mathbf{w}_{2^{n+1}}$. Let a_i be the map $\alpha \rightarrow \Gamma_i$ such that $a_i(j) = j$ for each $0 \leq j < \alpha$, and let $A_i = \{[a_i]\}$. See Figure 5.

Let Γ_j^i be the following element of \mathcal{G}_n for each $0 \leq i < j \leq 2^n$ such that $j-i < 2^n$: $\Gamma_j^i(0,1) = \mathbf{r}_{j-i}$, $\Gamma_j^i(0,2) = \mathbf{g}_i$, $\Gamma_j^i(1,2) = \mathbf{g}_j$, $\Gamma_j^i(k,l) = \mathbf{y}_{l-1}$ (for $0 \leq k \leq 1$ and $3 \leq l \leq \alpha-1$), and $\Gamma_j^i(k,l) = \mathbf{i}$ (for $2 \leq k < l \leq \alpha-1$). Let a_j^i be the map $\alpha \rightarrow \Gamma_j^i$ such that $a_j^i(k) = k$ for each $0 \leq k < \alpha$. See Figure 6.

Since $A_0 \neq 0$ in \mathfrak{C}_n , there is $(v_0, u_1, \dots, u_{\alpha-1}) \in h(A_0) \setminus h(0)$. For every $i \leq 2^n$, $A_0 \leq \mathbf{c}_0 A_i$, hence we have elements v_i ($i \leq 2^n$) such that $(v_i, u_1, \dots, u_{\alpha-1}) \in h(A_i)$. For any $0 \leq i < j \leq 2^n$ such that $j-i$ is a power of 2, we define A_j^i by recursion on $j-i$:

$$A_{i+1}^i = \mathbf{s}_2^1 \mathbf{c}_2 A_i \cdot \mathbf{s}_1^0 \mathbf{s}_2^1 \mathbf{c}_2 A_{i+1} \cdot \mathbf{c}_2 (\mathbf{c}_1 A_i \cdot \mathbf{s}_1^0 \mathbf{c}_1 A_i)$$

and for $l < n$,

$$A_{i+2^{l+1}}^i = \mathbf{s}_2^1 \mathbf{c}_2 A_i \cdot \mathbf{s}_1^0 \mathbf{s}_2^1 \mathbf{c}_2 A_{i+2^{l+1}} \cdot \mathbf{c}_2 (\mathbf{c}_1 A_i \cdot \mathbf{s}_1^0 \mathbf{c}_1 A_i) \cdot A_{i+2^l}^i ; A_{i+2^l}^i.$$

Claim 4.4 For any i, j such that $0 \leq i < j \leq 2^n$ and $j-i = 2^l$ for some $l < n$,

1. $A_j^i \leq \{[a_j^i]\}$
2. $(v_i, v_j, u_1, u_3, \dots, u_{\alpha-1}) \in h(A_j^i)$.

Proof: The proof is by induction on $j-i$. First, let $j = i+1$. Let $a : \alpha \rightarrow \Gamma$ be a map such that $a(k) = k$ for each $k < \alpha$ and assume that $[a] \in A_{i+1}^i$. By $A_{i+1}^i \leq \mathbf{s}_2^1 \mathbf{c}_2 A_i$, we get that $\Gamma(0,2) = \mathbf{g}_i$ and $\Gamma(0,k) = \mathbf{y}_{k-1}$ (for $3 \leq k \leq \alpha-1$). By $A_{i+1}^i \leq \mathbf{s}_1^0 \mathbf{s}_2^1 \mathbf{c}_2 A_{i+1}$, we have that $\Gamma(1,2) = \mathbf{g}_{i+1}$ and $\Gamma(1,k) = \mathbf{y}_{k-1}$ (for $3 \leq k \leq \alpha-1$). Thus $\Gamma(0,1)$ cannot be green, ivory, yellow or \mathbf{b}_k (for any $2 \leq k \leq \alpha-2$). Also $\Gamma(p,q) = \mathbf{i}$ (for $2 < p < q \leq \alpha-1$). Since $A_{i+1}^i \leq \mathbf{c}_2 (\mathbf{c}_1 A_i \cdot \mathbf{s}_1^0 \mathbf{c}_1 A_i)$, $\Gamma(0,1)$ cannot be \mathbf{b}_1 either. We have already seen that $\Gamma(0,2) = \mathbf{g}_i$ and that $\Gamma(1,2) = \mathbf{g}_{i+1}$. Thus the only possible (red) color for $(0,1)$ is \mathbf{r}_1 . Hence a must be a_{i+1}^i .

Note that $(v_i, u_1, \dots, u_{\alpha-1}) \in h(A_i)$ and $(v_{i+1}, u_1, \dots, u_{\alpha-1}) \in h(A_{i+1})$. Then, by the definition of the operations in set algebras, we get that $(v_i, v_{i+1}, u_1, u_3, \dots, u_{\alpha-1}) \in h(A_{i+1}^i)$.

Now assume the claim for all i, j such that $j-i = 2^k$ for some $k \leq l$. Let $a : \alpha \rightarrow \Gamma$ be such that $a(p) = p$ for each $p < \alpha$ and $[a] \in A_{i+2^{l+1}}^i$. By

$$A_{i+2^{l+1}}^i \leq \mathbf{s}_2^1 \mathbf{c}_2 A_i \cdot \mathbf{s}_1^0 \mathbf{s}_2^1 \mathbf{c}_2 A_{i+2^{l+1}} \cdot \mathbf{c}_2 (\mathbf{c}_1 A_i \cdot \mathbf{s}_1^0 \mathbf{c}_1 A_i),$$

we get that $\Gamma(0,2) = \mathbf{g}_i$, $\Gamma(1,2) = \mathbf{g}_{i+2^{l+1}}$, $\Gamma(p,q) = \mathbf{y}_{q-1}$ (for $0 < p < 1$ and $3 \leq q < \alpha-1$), $\Gamma(p,q) = \mathbf{i}$ (for $2 \leq p < q \leq \alpha-1$) and $\Gamma(0,1)$ must be red (cf. the argument above). For any map $b : \alpha \rightarrow \Delta$ such that $b(p) = p$ for every $p < \alpha$ and $[b] \in \mathbf{s}_2^1 \mathbf{c}_2 A_{i+2^l}^i \cdot \mathbf{s}_2^0 \mathbf{c}_2 A_{i+2^l}^i$, we have inductively that $\Delta(0,2) = \Delta(1,2) = \mathbf{r}_{2^l}$. Hence the only possible red color for $(0,1)$ in Δ is $\mathbf{r}_{2^{l+1}}$. By $[b]T_2[a]$, $\Delta(0,1) = \Gamma(0,1)$, i.e., $\Gamma(0,1) = \mathbf{r}_{2^{l+1}}$. Thus $a = a_{i+2^{l+1}}^i$.

Finally, (2) for $j = i+2^{l+1}$ follows from (1) and the definition of the operations in set algebras. ■

Then $(v_0, v_{2^{n-1}}, u_1, u_3, \dots, u_{\alpha-1}) \in h(A_{2^{n-1}}^0)$, $A_{2^{n-1}}^0 \leq \{[a_{2^{n-1}}^0]\}$, $(v_{2^{n-1}}, v_{2^n}, u_1, u_3, \dots, u_{\alpha-1}) \in h(A_{2^n}^{2^{n-1}})$, and $A_{2^n}^{2^{n-1}} \leq \{[a_{2^n}^{2^{n-1}}]\}$ by the claim above. By the proof of the above claim, we get that $(v_0, v_{2^n}, u_1, u_3, \dots, u_{\alpha-1}) \in h(A_{2^n}^0)$ and that the color of (v_0, v_{2^n}) should be \mathbf{r}_{2^n} . But there is no red color \mathbf{r}_k for $k > 2^n$, hence $A_{2^n}^0 = 0$ in \mathfrak{C}_n . Thus $(v_0, v_{2^n}, u_1, u_3, \dots, u_{\alpha-1}) \in h(0)$, whence $(v_0, u_1, u_2, u_3, \dots, u_{\alpha-1}) \in \mathbf{c}_1 \mathbf{c}_2 h(0) = h(\mathbf{c}_1 \mathbf{c}_2 0) = h(0)$ — contradiction. Lemma 4.3 has been proved. ■

We note that one can define valid equations witnessing the non-representability of the \mathfrak{C}_n ($n \in \omega$) as in the RA-case — we omit the details.

4.2 Games and ultraproduct

It remains to show that any non-trivial ultraproduct of the \mathfrak{C}_n ($n \in \omega$) is representable.

In [HH97b], two kinds of games are defined. The first type of game is formulated using colored graphs (see Definition 4.5 below), and the second is played on (networks for) cylindric algebras (the obvious modification of the game on relation algebras for cylindric algebras). The two games are equivalent in the sense that the existential player \exists has a winning strategy in the n -colored graph game iff she has a winning strategy in the network game played on the associated cylindric algebra \mathfrak{C}_n . Further, it is stated that an atomic cylindric algebra has a complete representation iff the existential player has a winning strategy in the ω -long game (on networks).

We will show representability of the ultraproduct by proving that the existential player can survive longer and longer games on \mathcal{G}_n as n increases. By the equivalence of the two types of games, she can achieve this in the network games as well. Then the combination of these winning strategies provide her with a winning strategy in the network game played on the ultraproduct. Hence the ultraproduct is a representable algebra.

Next we recall the definition of the n -colored graph game from [HH97b].

Definition 4.5 *Let \mathcal{G}_n be the class of n -colored graphs defined above.*

The game G_l^n ($l < \omega$) is defined as follows. The two players, \forall and \exists , build a chain of elements of \mathcal{G}_n : $\Gamma_0 \subseteq \Gamma_1 \subseteq \dots \subseteq \Gamma_l$ if l is finite, or $\Gamma_0 \subseteq \Gamma_1 \subseteq \dots$ if $l = \omega$.

$\Gamma_0 \in \mathcal{G}_n$ is arbitrary with $|\Gamma_0| = \alpha$. In each subsequent round i ($0 \leq i < l$),

- *\forall chooses a graph Φ from \mathcal{G}_n with $|\Phi| = \alpha$, a single node $\beta \in \Phi$ and a colored graph embedding $\lambda : \Phi \setminus \{\beta\} \rightarrow \Gamma_i$.*
- *\exists responds, if she can, with a finite colored graph $\Gamma_{i+1} \in \mathcal{G}_n$ and embeddings $\mu : \Gamma_i \rightarrow \Gamma_{i+1}$ and $\nu : \Phi \rightarrow \Gamma_{i+1}$ such that $\mu \circ \lambda$ and ν agree on $\Phi \setminus \{\beta\}$.*

\exists wins a match of the game G_l^n if she survives each round. We say that \exists has a winning strategy if she can win all matches.

If λ is an embedding, we denote the λ -image of Φ by $\lambda^*(\Phi)$.

Lemma 4.6 *Any non-trivial ultraproduct \mathfrak{C} of the \mathfrak{C}_n ($n \in \omega$) over ω is in RCA_α . Hence its $\{\text{intersection, cylindrifications, substitutions}\}$ -reduct is representable as well.*

Proof: First we prove that \exists can survive arbitrarily long matches in cofinitely many n -colored graph games.

Claim 4.7 *Let $l < n$ be arbitrary fixed elements of ω . \exists has a winning strategy in G_l^n .*

Proof: The proof below is a modification of the proof of the corresponding claim for the RA-case. Let us assume that we are in the p th round ($p < l$) and that $\Gamma_p \in \mathcal{G}_n$ has been already constructed.

Again we define the notion of a *red block*. Suppose that $u_1, \dots, u_{\alpha-1}$ are distinct nodes of Γ_p and that $\Gamma_p(u_i, u_j)$ is not green or yellow for any i, j . Let

$$W = \{w \in \Gamma_p : \Gamma_p(w, u_1) \text{ is green, and } \Gamma_p(w, u_i) = y_{i-1} \text{ for each } 2 \leq i < \alpha\}.$$

Suppose that

1. if $\Gamma_p(u_1, \dots, u_{\alpha-1}) = w_S$ then $S \supset \{i \leq 2^n : (\exists w \in W) \Gamma_p(u_1, w) = \mathfrak{g}_i\}$,
2. W can be linearly ordered ($w_1 < \dots < w_q$) in the following way: the map f from $\{1, \dots, q\}$ into the set $2^n + 1$ of indices of green atoms given by $\Gamma_p(w_i, u_1) = \mathfrak{g}_{f(i)}$ for every $1 \leq i \leq q$, satisfies $f(i) < f(j)$ whenever $1 \leq i < j \leq q$.

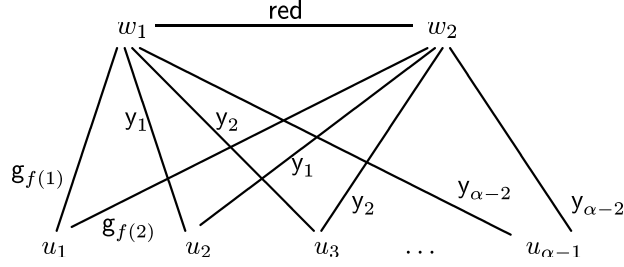

Figure 7: A red block

Note that the color of every (w_i, w_j) must be red (since (w_i, w_j) occurs in triangles with two green edges and two y_l ($1 \leq l \leq \alpha - 2$) edges). In such a situation, we will call the subgraph Γ of Γ_p with base $\{u_1, \dots, u_{\alpha-1}\} \cup W$ a *red block* with *center* $(u_1, \dots, u_{\alpha-1})$. We will say that w_i and w_{i+1} are *neighbors*, and that the *distance* of w_i from w_j is $|f(j) - f(i)|$. We use the notation $(u_1, \dots, u_{\alpha-1}, w_1, \dots, w_q)$ for such a red block. See Figure 7.

We note that a red block is a union of cones with the same center and pairwise distinct tints such that the edges between the apexes are colored with reds.

We now state the following induction hypothesis.

Induction hypothesis: For every red block Γ_p with base set $\{u_1, \dots, u_{\alpha-1}, w_1, \dots, w_q\}$ and center $(u_1, \dots, u_{\alpha-1})$ in the above notation, and for every $1 \leq i < j \leq k \leq q$,

1. $\Gamma_p(w_i, w_j) = r_{f(j)-f(i)}$ if $f(j) - f(i) \leq 2^{l-p}$;
2. $\Gamma_p(w_i, w_j) = r_t$ for some $t \leq 2^{l-1} + \dots + 2^{l-(j-i)}$,
3. $\Gamma_p(w_i, w_j) = r_t$ and $\Gamma_p(w_j, w_k) = r_s$ imply $\Gamma_p(w_i, w_k) = r_{t+s}$.

Note that $q \leq p + 1$, since, in each round of the game, at most one new point is created. The induction hypothesis implies that the largest index on a red atom (to label (w_1, w_q)) is at most $2^{l-1} + \dots + 2^{l-p}$. The initial graph Γ_0 trivially satisfies the induction hypothesis.

Assume that in this round, \forall plays $\Phi \in \mathcal{G}_n$ with $|\Phi| = \alpha$, a single node $\beta \in \Phi$, and a colored graph embedding $\lambda : \Phi \setminus \{\beta\} \rightarrow \Gamma_p$. As \mathcal{G}_n is closed under isomorphism, we may assume that the base of Φ is $\alpha = \{0, 1, \dots, \alpha - 1\}$ and that $\beta = 0$. We may also assume that if Φ is a cone with apex 0, then its center is $(1, 2, \dots, \alpha - 1)$. We note that, for any $y_1, \dots, y_{\alpha-1} \in \Phi$, if Φ is a cone with apex 0 and center $(y_1, \dots, y_{\alpha-1})$, then $(y_1, \dots, y_{\alpha-1}) = (1, 2, \dots, \alpha - 1)$.

\exists has to respond with a finite $\Gamma_{p+1} \in \mathcal{G}_n$ and embeddings $\mu : \Gamma_p \rightarrow \Gamma_{p+1}$ and $\nu : \Phi \rightarrow \Gamma_{p+1}$ such that $\mu(\lambda(i)) = \nu(i)$ for each $1 \leq i \leq \alpha - 1$.

We can assume that

- (*) there is no node $\gamma \in \Gamma_p$ such that the colored graph induced by Γ_p on nodes $\{\gamma\} \cup \text{rng}(\lambda)$ is isomorphic to Φ by an isomorphism extending λ ,

because otherwise \exists can respond with $\Gamma_{p+1} = \Gamma_p$, μ the identity, and $\nu(0) = \gamma$, $\nu(i) = \lambda(i)$ ($1 \leq i \leq \alpha - 1$).

\exists defines Γ_{p+1} by extending Γ_p with a single new node w , and letting μ be the identity map on Γ_p , $\nu(i) = \lambda(i)$ ($1 \leq i \leq \alpha - 1$), and $\nu(0) = w$. She then colors the new edges of the graph (those edges (w, u) for $u \in \Gamma_p \setminus \text{rng}(\lambda)$); she also colors some $(\alpha - 1)$ -tuples. Her strategy in the coloring is as follows: \exists tries to color the edges first using ivory; then, if this fails, black; and finally, if all else fails, red with a carefully chosen index. She colors “new” $(\alpha - 1)$ -tuples — those including w and at least one node of $\Gamma_p \setminus \text{rng}(\lambda)$, and not involving green or yellow edges — by whites whose

indices are minimal (in the sense that she uses w_S only if there is an i -cone in the graph with the above $(\alpha - 1)$ -tuple as its center and $i \in S$).

Let $\lambda(i) = v_i$ ($1 \leq i \leq \alpha - 1$). The colors of (w, v_i) are defined as $\Phi(0, i)$, i.e., these colors are determined by \forall 's choice of Φ and λ . Similarly, any $(\alpha - 1)$ -tuple of points from $\text{rng}(\nu)$ is colored by the same white color (if any) as its pre-image under ν .

We show how \exists chooses the remaining edge colors (w', w) with $w' \in \Gamma_p \setminus \text{rng}(\lambda)$. First, she colors those edges (w', w) such that either $(w, v_1, \dots, v_{\alpha-1})$ or $(w', v_1, \dots, v_{\alpha-1})$ is not a cone. She colors (w, w') using ivory if there is no i such that (w, v_i) and (w', v_i) are both green. Otherwise she lets (w, w') have \mathbf{b}_l for the smallest $1 \leq l \leq \alpha - 1$ such that there is no i for which both (w, v_i) and (w', v_i) have color \mathbf{y}_l . It is easy to check that one of the above cases holds, and that no inconsistent triangle is created involving the nodes $w, w', v_1, \dots, v_{\alpha-1}$. Further, no inconsistent triangle is created on w, w', w'' (w', w'' with the above property), since all triangles with two sides ivory and/or black are consistent.

Now \exists colors those edges (w', w) (if any) such that both $(w, v_1, \dots, v_{\alpha-1})$ and $(w', v_1, \dots, v_{\alpha-1})$ are cones. Assume there are some. Then w is the apex of an m -cone (say) with center $(v_1, \dots, v_{\alpha-1})$. As $\Phi \in \mathcal{G}_n$, there are no green or yellow edges in the graph induced on $\{v_1, \dots, v_{\alpha-1}\}$; so $\Gamma_p(v_1, \dots, v_{\alpha-1}) = \Phi(1, \dots, \alpha - 1) = w_S$ for some $S \subset 2^n + 1$ with $m \in S$. Let

$$W = \{u \in \Gamma_p : u \text{ is the apex of a cone with center } (v_1, \dots, v_{\alpha-1})\} \neq \emptyset.$$

We claim that $W \cup \{v_1, \dots, v_{\alpha-1}\}$ is the base of a red block in Γ_p . Suppose that $W = \{w_1, \dots, w_q\}$. Let the tint of the cone $(w_i, v_1, \dots, v_{\alpha-1})$ be denoted by $f(i)$: i.e., (w_i, v_1) has color $\mathbf{g}_{f(i)}$ ($1 \leq i \leq q$). By enumerating W appropriately, we may assume that if $i < j$ then $f(i) \leq f(j)$.

We first show that $S \supset \{f(1), \dots, f(q)\}$. Certainly, $S \supseteq \{f(1), \dots, f(q)\}$, since $\Gamma_p \in \mathcal{G}_n$. Since $\Gamma_p, \Phi \in \mathcal{G}_n$, the only $(\alpha - 1)$ -tuples of elements of $\{v_1, \dots, v_{\alpha-1}, w_i\}$ (any i), and of $\{v_1, \dots, v_{\alpha-1}, w\}$, with a white color are permutations of $(v_1, \dots, v_{\alpha-1})$. Thus, if $m = f(i)$ for some i , the colored graphs induced on $\{v_1, \dots, v_{\alpha-1}, w\}$ ($\cong \Phi$) and $\{v_1, \dots, v_{\alpha-1}, w_i\}$ are isomorphic. So by $(*)$, we can assume that the tint m of the cone with apex w is different from $f(i)$ for any $1 \leq i \leq q$. As $m \in S$, we are done.

Now we show that f is one-one. Suppose not. Let $w_i, w_j \in W$ be distinct such that $f(i) = f(j)$, and let $X = \{w_i, w_j, v_1, \dots, v_{\alpha-1}\}$. Now $|X| = \alpha + 1$. Hence, not all of the nodes in this set were built in a single round. Since only one node is added in each non-initial round, some node x (say) in this set was constructed most recently in the game. Clearly, when x was added, \exists must have chosen the color of some edge (x, y) for some $y \in X \setminus \{x\}$. Choose such a y .

Suppose that $x = v_k$ for some k . Now $\Gamma_p(v_k, w_i), \Gamma_p(v_k, w_j)$ are both yellow or green, and \exists never uses these colors. So $y \in \{v_1, \dots, v_{\alpha-1}\}$. It follows that \exists chose the white color $\Gamma_p(v_1, \dots, v_{\alpha-1}) = w_S$. Since there was evidently no m -cone at that stage with center $(v_1, \dots, v_{\alpha-1})$, she would have chosen S with $m \notin S$ — a contradiction, since we know $m \in S$.

Suppose alternatively that $x = w_i$ (the case $x = w_j$ is symmetrical). The graph induced on $\{w_i, v_1, \dots, v_{\alpha-1}\}$ involves $\alpha - 1$ distinct edges containing w_i and labeled green or yellow; because \exists never chooses these colors, we see that in the round when w_i was added, \forall chose as his move a colored graph in \mathcal{G}_n with nodes $\{z, v'_1, \dots, v'_{\alpha-1}\}$, say, isomorphic to that induced on $\{w_i, v_1, \dots, v_{\alpha-1}\}$, the distinguished node z , and the embedding $\lambda' : v'_k \rightarrow v_k$ ($1 \leq k < \alpha$). But as $f(i) = f(j)$ and only $(\alpha - 1)$ -tuples without yellow or green edges are labeled with white colors, the cones on the bases $\{w_i, v_1, \dots, v_{\alpha-1}\}$ and $\{w_j, v_1, \dots, v_{\alpha-1}\}$ are isomorphic. So the extension of λ' that maps z to w_j is a colored graph embedding. Hence, \exists would not have needed to extend the graph by adding x . By her strategy, she would not have done so — another contradiction.

Therefore, f is indeed one-one, and the claim is proved: $W \cup \{v_1, \dots, v_{\alpha-1}\}$ is a red block. So it must satisfy the induction hypothesis.

We claim next that \exists can find appropriate red colors for each (w, w_j) ($1 \leq j \leq q$) such that conditions 1–3 of the induction hypothesis hold (when we replace p by $p + 1$).

Indeed, the same construction as in the RA-case works. Let $w_j \in W$ be such that $|m - f(j)|$ is minimal. If $|m - f(j)| \leq 2^{l-p-1}$, then she lets $\Gamma_{p+1}(w_j, w) = \mathbf{r}_{|m-f(j)|}$. If $|m - f(j)| > 2^{l-p-1}$,

then she lets $\Gamma_{p+1}(w_j, w) = r_{2^{l-p-1}}$. \exists labels the other edges (w_k, w) by using a red atom indexed by the sum (if $w_k < w_j$ and $f(j) < m$, or $w_j < w_k$ and $m < f(j)$) or the difference (if $w_j < w_k$ and $f(j) < m$, or $w_k < w_j$ and $m < f(j)$) of the indices of the reds on (w_k, w_j) and (w_j, w) . It can be checked that these red colors exist, and conditions 1–3 of the induction hypothesis hold for $(v_1, \dots, v_{\alpha-1}, w_1, \dots, w, \dots, w_q)$.

Finally, \exists colors those (new) $(\alpha - 1)$ -tuples which do not include green or yellow edges. Let $(u_1, \dots, u_{\alpha-1})$ be such a sequence. She colors it by w_S , where

$$S = \{i \leq 2^n : (\exists v \in \Gamma_{p+1})(u_1, \dots, u_{\alpha-1}, v) \text{ is an } i\text{-cone} \\ \text{with center } (u_1, \dots, u_{\alpha-1})\}.$$

It remains to show that the induction hypothesis holds for *any* red block Γ of Γ_{p+1} . First, note that if a red block satisfied the induction hypothesis for p (in the previous round) and it is still a red block in Γ_{p+1} , then it satisfies the induction hypothesis for $p+1$ as well. We make the following observation about “new” red blocks that are not red blocks of Γ_p (cf. above): any new red block must contain the new node, w : w cannot be in the *center* of such a block, since in that case \exists would have labeled the center in this round (round p) with a white w_S for “minimal” S , and the minimality violates the first condition defining ‘red block’; so w is the *apex* of the new red block; and its center must be $(v_1, \dots, v_{\alpha-1})$ because all apex-base edges must be yellow or green and \exists never uses these colors. Thus, the only possible new red block is $(v_1, \dots, v_{\alpha-1}, w_1, \dots, w, \dots, w_q)$, where $(v_1, \dots, v_{\alpha-1}, w_1, \dots, w_q)$ was a red block. We have already seen that this red block satisfies the induction hypothesis.

Similarly to the RA-case, one can easily check that the coloring is consistent, i.e., that $\Gamma_{p+1} \in \mathcal{G}_n$.

We can finish the proof as in the RA-case. The largest index on red colors used by \exists so far is at most $2^{l-1} + 2^{l-2} + \dots + 2^{l-p-1} < 2^l$, since, in the k th round, she labeled an edge (w, w') of neighboring points w, w' with r_j such that $j < 2^{l-k-1}$. Thus, in the remaining rounds of the game, \forall cannot force her to use a non-existing red r_i ($i \geq 2^n$). In any red block, if the distance $|f(i) - f(j)|$ between two points w_i and w_j is “small”, i.e., smaller than 2^{l-p-1} , then she used $r_{|f(i)-f(j)}$ to label (w_i, w_j) . Thus, in the remaining rounds, she has enough indices between 1 and $|f(i) - f(j)|$ to label any edge (w_i, w) and (w, w_j) “inserted” into (w_i, w_j) . This shows that she can survive l rounds without arriving at the impossible task of using a non-existing red color. This finishes the proof of Claim 4.7. ■

By the equivalence of network and graph games, the above claim ensures that \exists has winning strategies for the l -round games on cofinitely many algebras. These winning strategies provide her with a winning strategy in the game played on the ultraproduct. The argument here is much the same as in the RA-case; we omit the details. ■

4.3 Diagonal-free reducts

In this section we strengthen Theorem 2.7 by showing that the {intersection, cylindrifications}-subreduct of representable cylindric algebras of dimension at least three is not finitely axiomatizable.

We already mentioned that RCA_α is not finitely axiomatizable whenever $\alpha \geq 3$. Non-finite axiomatizability holds for the diagonal-free fragment of RCA_α as well, a result of Johnson [Joh69]. We will give a similar proof below.

Let \mathfrak{A} be an α -dimensional cylindric algebra and a be an element of \mathfrak{A} . The *dimension set* Δa of a is defined as

$$\Delta a = \{i < \alpha : c_i a \neq a\}.$$

[HMT, Theorem 5.1.51] states that an α -dimensional cylindric algebra is representable iff its diagonal-free reduct is representable, provided that the algebra is generated by $(\alpha - 1)$ -dimensional elements. Below we will show that a similar theorem holds for the appropriate reducts.

Let $\alpha > 3$ be fixed. First we define the algebras $\mathfrak{B}'_n \in \mathbf{SRd}_{\{\cdot, \mathbf{c}_i, \mathbf{d}_{ij}; i, j < \alpha\}} \mathbf{RCA}_\alpha$ ($n \in \omega$) as follows. Let us recall that we defined atomic cylindric algebras \mathfrak{C}_n in Section 4, and that \mathfrak{B}_n is the $\{\cdot, \mathbf{c}_i, \mathbf{s}_j^i : i, j < \alpha\}$ -reduct of \mathfrak{C}_n . Now let \mathfrak{B}'_n be that subalgebra (of similarity type $\{\cdot, \mathbf{c}_i, \mathbf{d}_{ij} : i, j < \alpha\}$) of the $\{\cdot, \mathbf{c}_i, \mathbf{d}_{ij} : i, j < \alpha\}$ -reduct of \mathfrak{C}_n that is generated by the atoms of \mathfrak{C}_n .

Claim 4.8 *The algebras \mathfrak{B}'_n ($n \in \omega$) have the following properties:*

1. *they are generated by $(\alpha - 1)$ -dimensional elements,*
2. *they are not representable as set algebras and*
3. *any non-trivial ultraproduct of \mathfrak{B}'_n ($n \in \omega$) is representable as a set algebra.*

Proof: 1: It suffices to show that

$$\{[a]\} = \prod \{\mathbf{c}_i\{[a]\} : i < \alpha\}$$

for any $a \in K_n$. Say, $a : \alpha \rightarrow \Gamma$ with $\Gamma \in \mathcal{G}_n$.

Clearly, \leq holds. For the other direction assume that $b : \alpha \rightarrow \Delta$ and $[a] \neq [b]$. We show that $[b]$ cannot be an element of the right hand side. Since a and b are not equivalent, we can assume that

1. $(\exists i, j < \alpha) \Delta(b(i), b(j)) \neq \Gamma(a(i), a(j))$ or
2. $(\exists i_1, \dots, i_{\alpha-1} < \alpha) \Delta(b(i_1), \dots, b(i_{\alpha-1})) \neq \Gamma(a(i_1), \dots, a(i_{\alpha-1}))$.

In the first case, let $k \notin \{i, j\}$. We claim that $[b] \notin \mathbf{c}_k\{[a]\}$. Assume to the contrary that $(\forall i, j \in \alpha \setminus \{k\}) \Delta(b(i), b(j)) = \Gamma(a(i), a(j))$. But, by the choice of k and the assumption, $(\exists i, j \in \alpha \setminus \{k\}) \Delta(b(i), b(j)) \neq \Gamma(a(i), a(j))$, contradiction. In the second case, choose $k \notin \{i_1, \dots, i_{\alpha-1}\}$ and derive a contradiction in the same way.

2: Recall that the substitutions \mathbf{s}_j^i are defined using \cdot, \mathbf{c}_i and \mathbf{d}_{ij} ($i, j < \alpha$). Thus all the elements of \mathfrak{B}_n that we defined and used in the non-representability proof of \mathfrak{B}_n are in fact elements of \mathfrak{B}'_n ; cf. the proof of Lemma 4.3. Hence the same argument works for the non-representability of \mathfrak{B}'_n .

3: The ultraproduct of the \mathfrak{B}'_n ($n \in \omega$) is clearly representable, since it is a subalgebra of a reduct of the ultraproduct of the \mathfrak{C}_n ($n \in \omega$), which is representable by Lemma 4.6. ■

Now we claim the following variant of [HMT, Theorem 5.1.51].

Theorem 4.9 *Let $\mathfrak{A} \in \mathbf{CA}_\alpha$. Let $\mathfrak{B} \subset \mathfrak{Rd}_{\{\cdot, \mathbf{c}_i, \mathbf{d}_{ij}; i, j < \alpha\}} \mathfrak{A}$ and assume that \mathfrak{B} is generated by $(\alpha - 1)$ -dimensional elements. Let \mathfrak{C} be the diagonal-free reduct of \mathfrak{B} and suppose that \mathfrak{C} is representable as a set algebra. Then \mathfrak{B} is representable as well.*

Proof: The easiest way to prove the above theorem is to repeat the proof of [HMT, Theorem 5.1.51] with minimal and straightforward modifications. Since this proof is rather technical and long, we just give a sketch (and give the numbers of the corresponding lemmas from [HMT] in brackets).

Assume that \mathfrak{C} is representable, via the isomorphism h , as a set algebra $\mathfrak{D} \subseteq (\mathcal{P}(\prod \{U_i : i < \alpha\}), \cdot, \mathbf{c}_i)_{i < \alpha}$. We can assume that $U_0 = \dots = U_{\alpha-1} = U$ and that $h(\mathbf{d}_{ij}) \supseteq \{s \in {}^\alpha U : s(i) = s(j)\}$ (cf. 5.1.48).

We define the relation R on U as follows: let $i, j < \alpha$ be distinct indices, then

$$R = \{(u, v) \in U \times U : s(i) = u \text{ and } s(j) = v \text{ for some } s \in h(\mathbf{d}_{ij})\}.$$

It can be shown that the definition of R is independent of the choice of i and j and that R is an equivalence relation on U (see 5.1.49).

Next we let

$$E = \{x \in C : (\forall s, t \in {}^\alpha U)[(\forall i < \alpha)(s(i), t(i)) \in R \rightarrow (s \in h(x) \leftrightarrow t \in h(x))]\},$$

that is, E consists of those elements of \mathfrak{C} which cannot “distinguish” between equivalent sequences s and t . It can be shown that $\{x \in C : \Delta x \neq \alpha\} \subseteq E$, and that E is a subuniverse of \mathfrak{B} (cf. 5.1.50). Thus E contains the generators of \mathfrak{B} , whence $E = B = C$. Then we can factorize U by R so that \mathfrak{C} can be embedded into $(\mathcal{P}({}^\alpha(U/R)), \cdot, \mathbf{c}_i)_{i < \alpha}$ via the isomorphism f given by

$$f(x) = \{(s(i)/R : i < \alpha) \in {}^\alpha(U/R) : s \in h(x)\}$$

(see 5.1.39). Moreover, the diagonals are preserved:

$$f(\mathbf{d}_{ij}) = \{s \in {}^\alpha(U/R) : s(i) = s(j)\}$$

because of the definition of R and f .

Hence \mathfrak{B} can be embedded into $(\mathcal{P}({}^\alpha(U/R)), \cdot, \mathbf{c}_i, \mathbf{d}_{ij})_{i, j < \alpha}$ as desired. ■

Finally we prove Corollary 2.8.

Proof of Corollary 2.8: By Claim 4.8, the algebras \mathfrak{B}'_n ($n \in \omega$) are not representable and are generated by $(\alpha - 1)$ -dimensional elements. Then by Theorem 4.9, their diagonal-free reducts \mathfrak{C}'_n ($n \in \omega$) are not representable either. On the other hand, the ultraproduct of \mathfrak{C}'_n ($n \in \omega$) is representable, since it is the diagonal-free reduct of the ultraproduct of \mathfrak{B}'_n ($n \in \omega$) which is a representable algebra by Claim 4.8. ■

5 Conclusions

Let us mention some open problems.

1. Is the $\{\cdot, ;, 1'\}$ -subreduct of RRA finitely axiomatizable?
2. Bredikhin [Bre77] showed that the $\{;, \smile\}$ -subreduct of RRA is not finitely axiomatizable. Is it true for any generalized subreduct of RRA in which composition and converse are definable?
3. Find (quasi)equations witnessing the non-finitizability of $\mathbf{SRd}_{\{\cdot, \mathbf{c}_i : i < \alpha\}} \mathbf{RCA}_\alpha$ (for $\alpha \geq 3$).
4. Investigate (non-)finite axiomatizability of subreducts of the classes \mathbf{RA}_n and $\mathbf{S}\mathfrak{Ra}^* \mathbf{CA}_n$. These classes can be viewed as n -dimensional analogues of RRA. See, e.g., [Mad83; Mad89]. For example, we conjecture that the argument for subreducts of RRA in the current paper can be generalized to prove that for all finite $n \geq 5$, if \mathbf{K} is a generalized subreduct of \mathbf{RA}_n or of $\mathbf{S}\mathfrak{Ra}^* \mathbf{CA}_n$ in which intersection, relation composition, and converse are term definable, then \mathbf{K} is not axiomatizable by any finite set of first-order sentences, and the equational theory of \mathbf{K} is not finitely based. It would suffice to show that $\mathfrak{A}_n \notin \mathbf{RA}_5$, for each finite n , where \mathfrak{A}_n is the relation algebra constructed in Section 3.

Acknowledgements: Thanks are due to an anonymous referee, Hajnal Andr eka and the former and present members of the Group of Algebraic Logicians in London: Robin Hirsch,  gnes Kurucz, Maarten Marx and Mark Reynolds, for their helpful comments.

References

- [And88] H. ANDRÉKA, “On the representation problem of distributive semilattice-ordered semigroups”, preprint, Mathematical Institute of the Hungarian Academy of Sciences, 1988.
- [And90] H. ANDRÉKA, “The equational theories of representable positive cylindric and relation algebras are decidable”, preprint, Mathematical Institute of the Hungarian Academy of Sciences, 1990.
- [And91] H. ANDRÉKA, “Representation of distributive lattice-ordered semigroups with binary relations”, *Algebra Universalis*, 28:12–25, 1991.
- [AM94] H. ANDRÉKA & SZ. MIKULÁS, “Lambek calculus and its relational semantics: completeness and incompleteness”, *Journal of Logic, Language and Information*, 3:1–37, 1994.
- [Ben96] J. VAN BENTHEM, *Exploring logical dynamics*, Studies in Logic, Language and Information, CSLI Publications and FoLLI, 1996.
- [Bre77] D. A. BREDIKHIN, “Abstract characteristic of some classes of algebras of relations”, (in Russian), *Algebra and Theory of Numbers*, Nalchik, v(2):3–19, 1977.
- [Bre93] D. A. BREDIKHIN, “The equational theory of relation algebras with positive operations”, (in Russian), *Izv. Vyssh. Uchebn. Zaved. Math.*, 3:23–30, 1993.
- [BS78] D. A. BREDIKHIN & B. M. SCHEIN, “Representation of ordered semigroups and lattices by binary relations”, *Colloquium Mathematicum*, 39:1–12, 1978.
- [Com91] S.D. COMER, “A remark on representable positive cylindric algebras”, *Algebra Universalis*, 28:150–151, 1991.
- [Dün93] I. DÜNTSCH, “A note on cylindric lattices”, in: C. Rauszer (ed.), *Algebraic Methods in Logic and in Computer Science*, Banach Center Publications, Vol.28:231–238, 1993.
- [Hai91] M. HAIMAN, “Arguesian lattices which are not type I.”, *Algebra Universalis*, 28:128–137, 1991.
- [Han95] B. HANSEN, “Finitizability questions for some reducts of cylindric algebras”, in: I. Csirmaz, D.M. Gabbay, M. de Rijke (eds.), *Logic Colloquium '92*, Studies in Logic, Language and Information, CSLI Publications and FoLLI, pp:115–134, 1995.
- [HMT] L. HENKIN, J.D. MONK & A. TARSKI, *Cylindric Algebras I., II.*, North-Holland, Amsterdam, 1971, 1985.
- [HH97] R. HIRSCH & I. HODKINSON, “Axiomatizing various classes of relation and cylindric algebras”, *Logic Journal of the IGPL*, 5(2):209–229, 1997.
- [HH97a] R. HIRSCH & I. HODKINSON, “Step by step — building representations in algebraic logic”, *Journal of Symbolic Logic*, 62:225–279, 1997.
- [HH97b] R. HIRSCH & I. HODKINSON, “Complete representations in algebraic logic”, *Journal of Symbolic Logic*, 62:816–847, 1997.
- [Hod93] W. HODGES, *Model theory*, Cambridge University Press, 1993.
- [JM97] P. JIPSEN & R. MADDUX, “Nonrepresentable sequential algebras”, *Logic Journal of the IGPL*, 5(4):565–574, 1997.
- [Joh69] J.S. JOHNSON, “Nonfinitizability of classes of representable polyadic algebras”, *Journal of Symbolic Logic*, 34:344–352, 1969.

- [Jón59] B. JÓNSSON, “Representation of modular lattices and of relation algebras”, *Transactions of the AMS*, 92:449–464, 1959.
- [Lyn50] R.C. LYNDON, “The representation of relational algebras”, *Ann. of Math.*, 51:707–729, 1950.
- [Kar94] B. VON KARGER, “The class of representable sequential algebras is not finitely axiomatizable”, draft, 1994.
- [Mad83] R.D. MADDUX, “A sequent calculus for relation algebras”, *Annals of Pure and Applied Logic*, 25:73–101, 1983.
- [Mad89] R.D. MADDUX, “Non-finite axiomatizability results for cylindric and relation algebras”, *Journal of Symbolic Logic*, 54(3):951–974, 1989.
- [Mon64] J.D. MONK, “On representable relation algebras”, *Michigan Mathematical Journal*, 11:207–210, 1964.
- [Mon69] J.D. MONK, “Nonfinitizability of classes of representable cylindric algebras”, *Journal of Symbolic Logic*, 34:331–343, 1969.